

Spannzange / collet ER32 DIN6499  
 Spannbereich / clamping range: 2,0 - 20,0

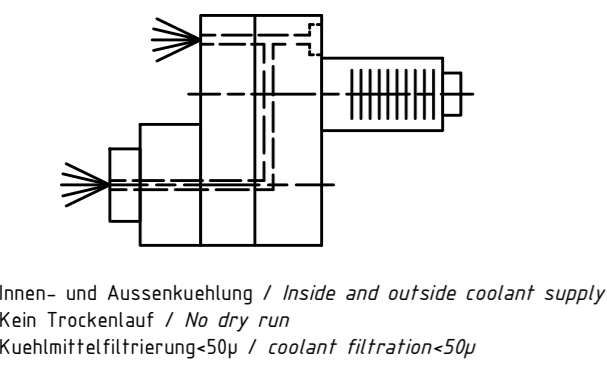
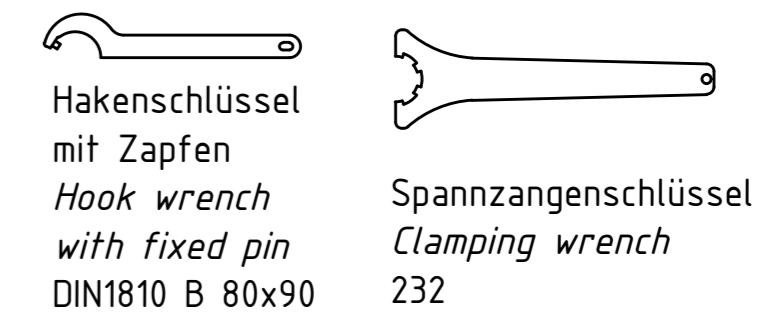
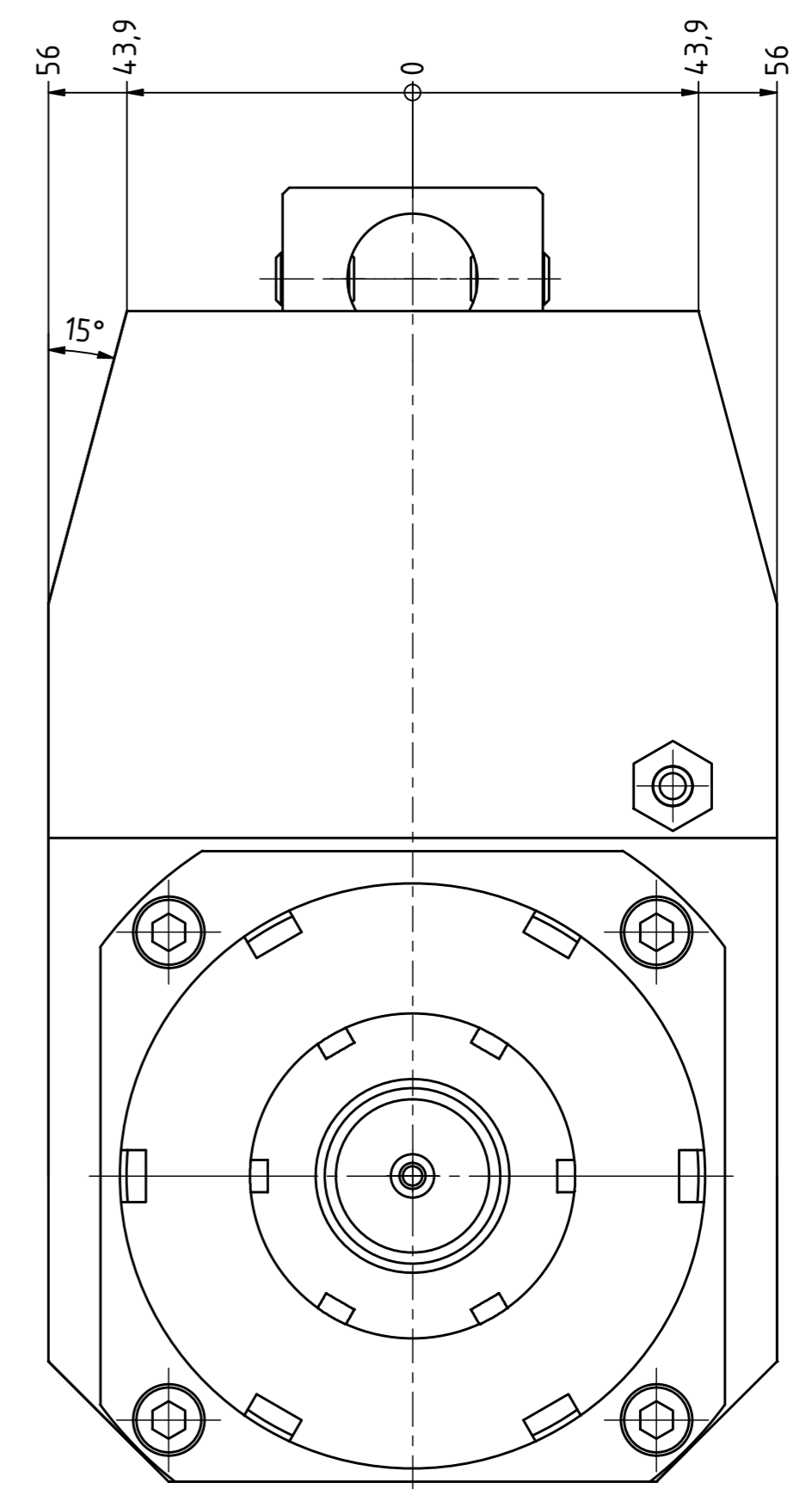
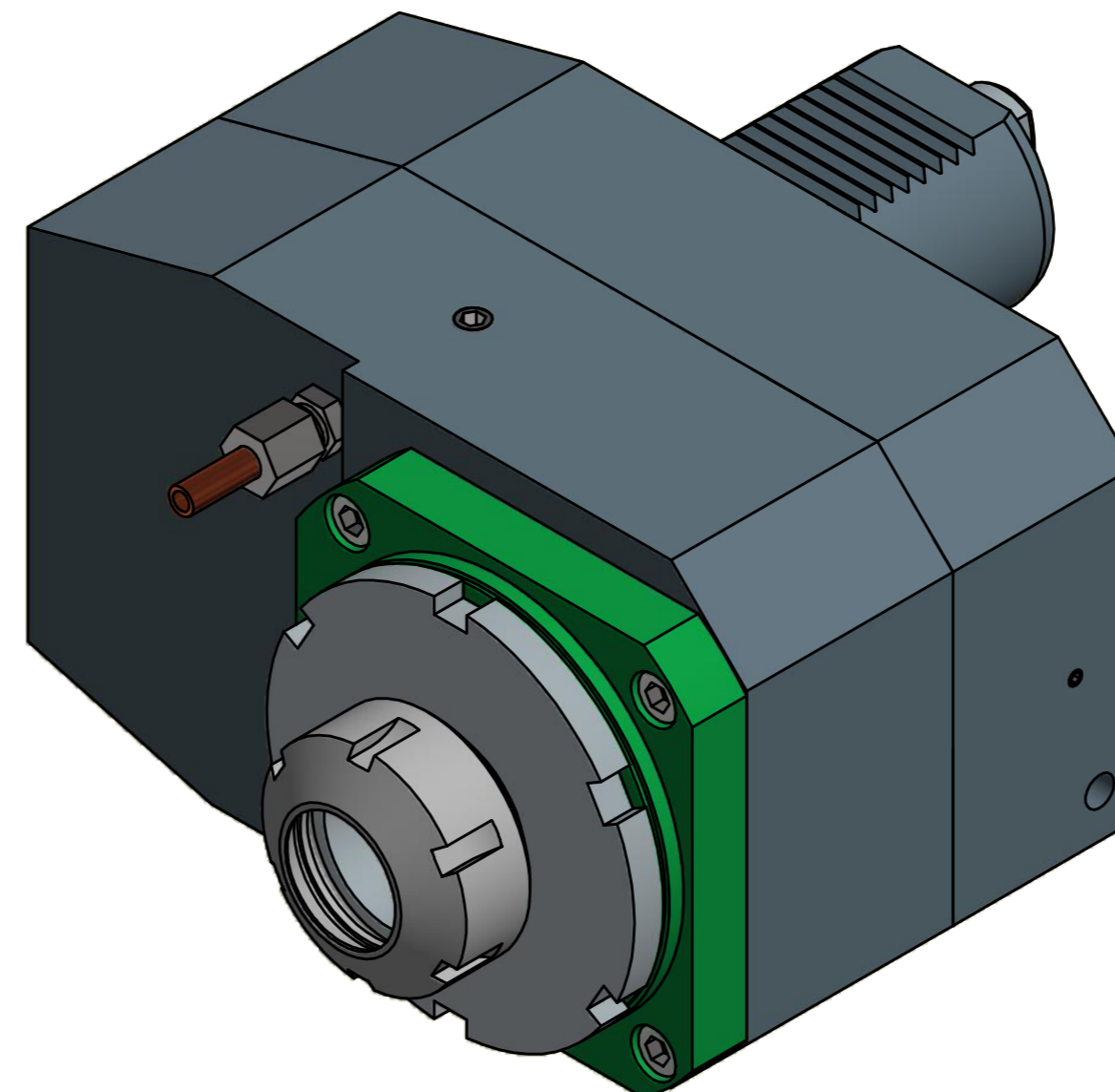

Bemerkung - Note Nicht ohne Kuehlmittel betreiben! Not for use without coolant-fluid!	Technische Daten - technical data Weight = 15,149 [kg]
	Torque max. (M1/M2) = 100 / 50 [Nm]
	Speed max. (n1/n2) = 4000 / 8000 [1/min]
	Gear ratio (i)=n1:n2 = 1:2
	Pressure (pmax) = 70 [bar]

Benennung - Title  
**Axial Bohr u. Fräskopf achsversetzt**  
 Ax. drill. and mill. head offset

<b>EWS</b> <small>EWS Weigle GmbH &amp; Co. KG          Maybachstr. 1          D-73066 Uhlingen          www.ews-tool.de</small>	Technische Aenderungen vorbehalten! Subject to technical modifications! IDENT: DEWS062041
	Nr. - No. 50.50321809RIK11PIN63

Copyright **EWS Tool Technologies**  
 Weitergabe und Vervielfaeltigung dieser Unterlage,  
 Verwertung und Mitteilung ihres Inhalts nicht  
 gestattet, soweit nicht ausdrecklich zugestanden.  
 Zuwiderhandlungen verpflichten zu Schadenersatz.

MNR. REV: -/A  
 209205

**QR**