

Spannzange / collet ER25 DIN6499  
 Spannbereich / clamping range: 1,0 - 16,0

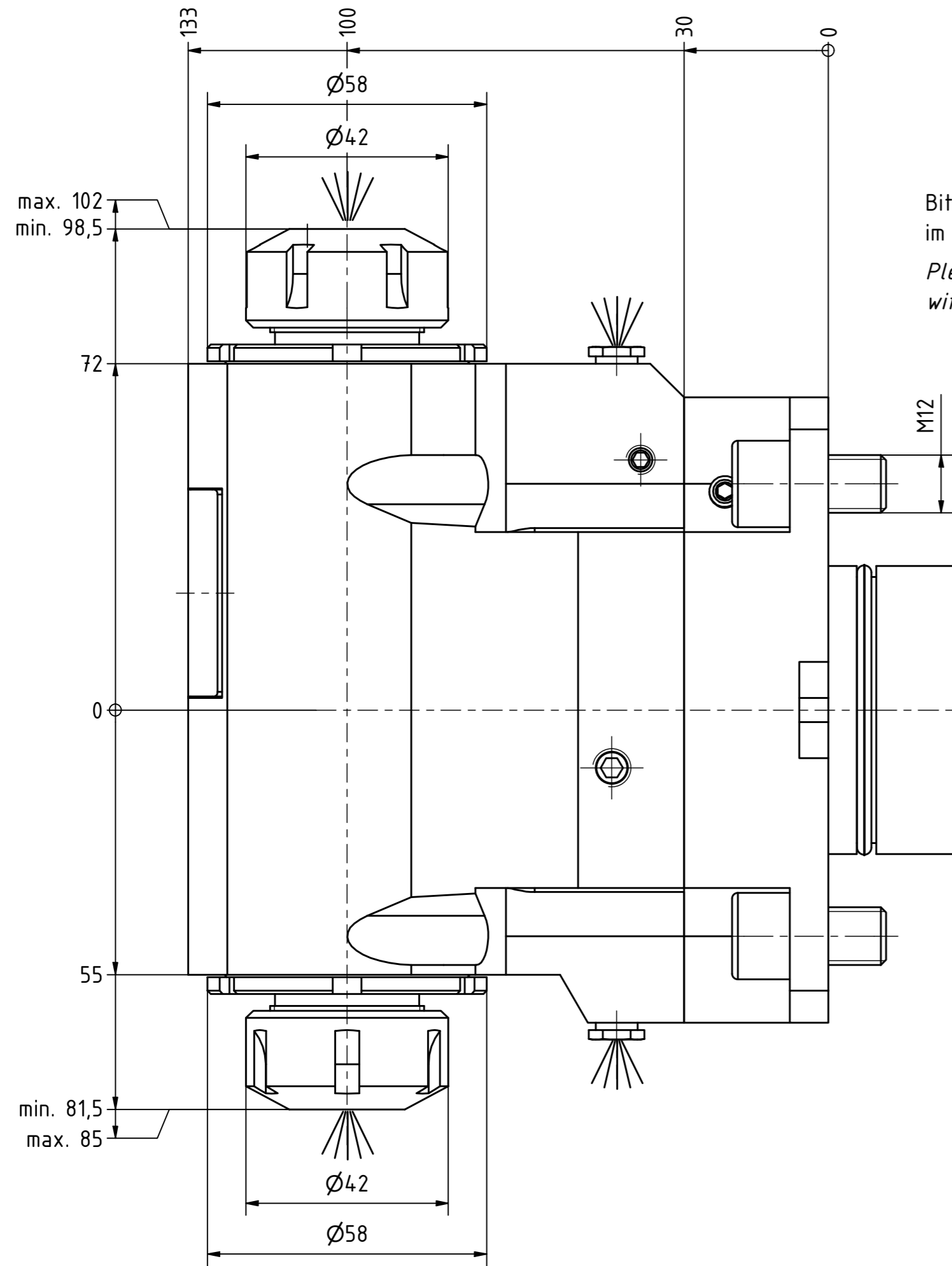

Bitte überprüfen Sie, ob der Werkzeughalter auf ihrem Revolver im Maschinenraum ohne Kollision durchschwenken kann.  
 Please check the work space of the machine for interferences with the tool holder, especially the swiveling diameter.

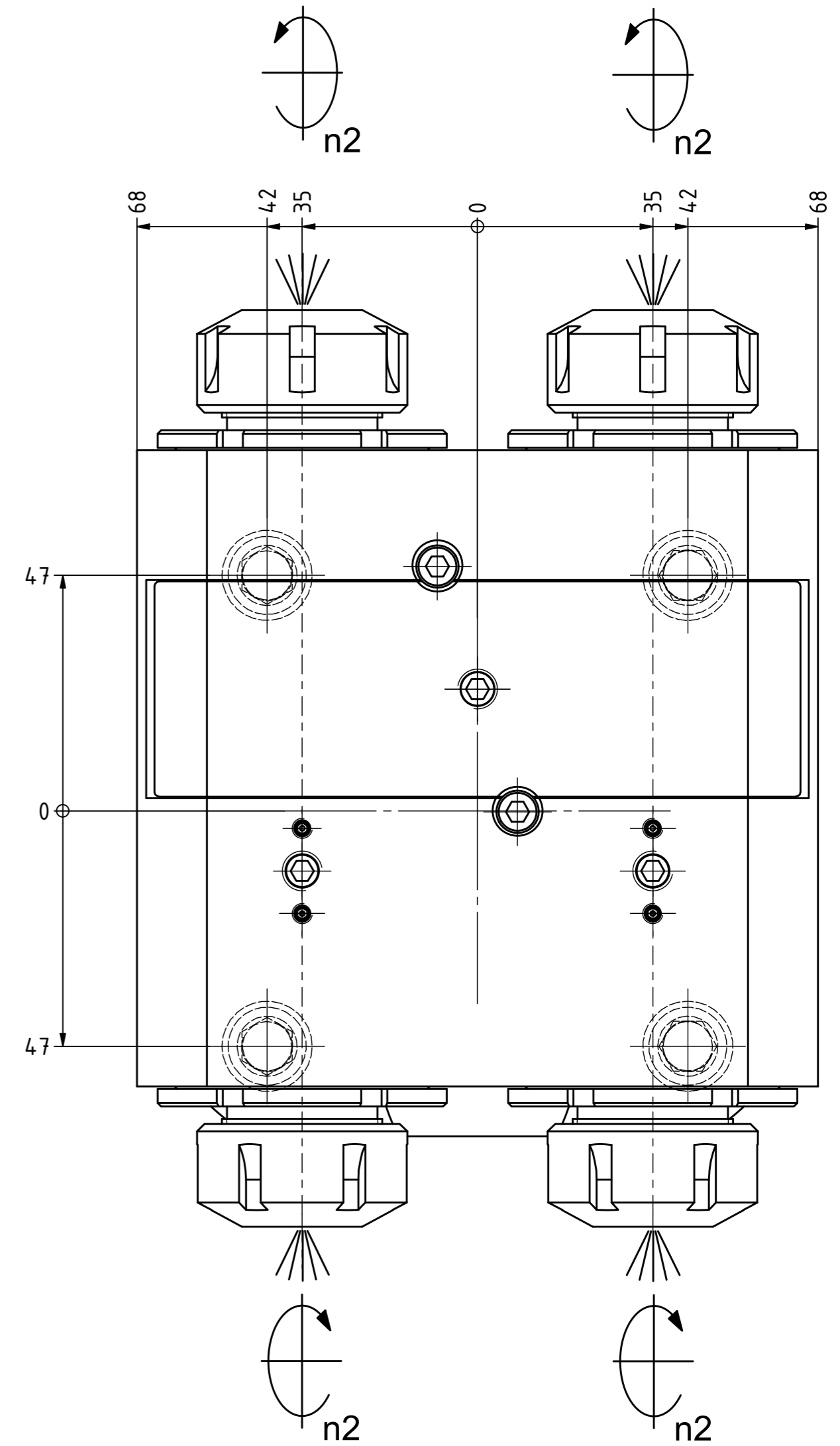

Spannzange / collet ER25 DIN6499  
 Spannbereich / clamping range: 1,0 - 16,0

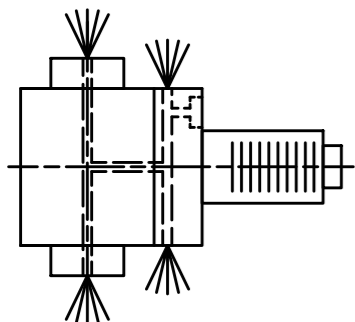
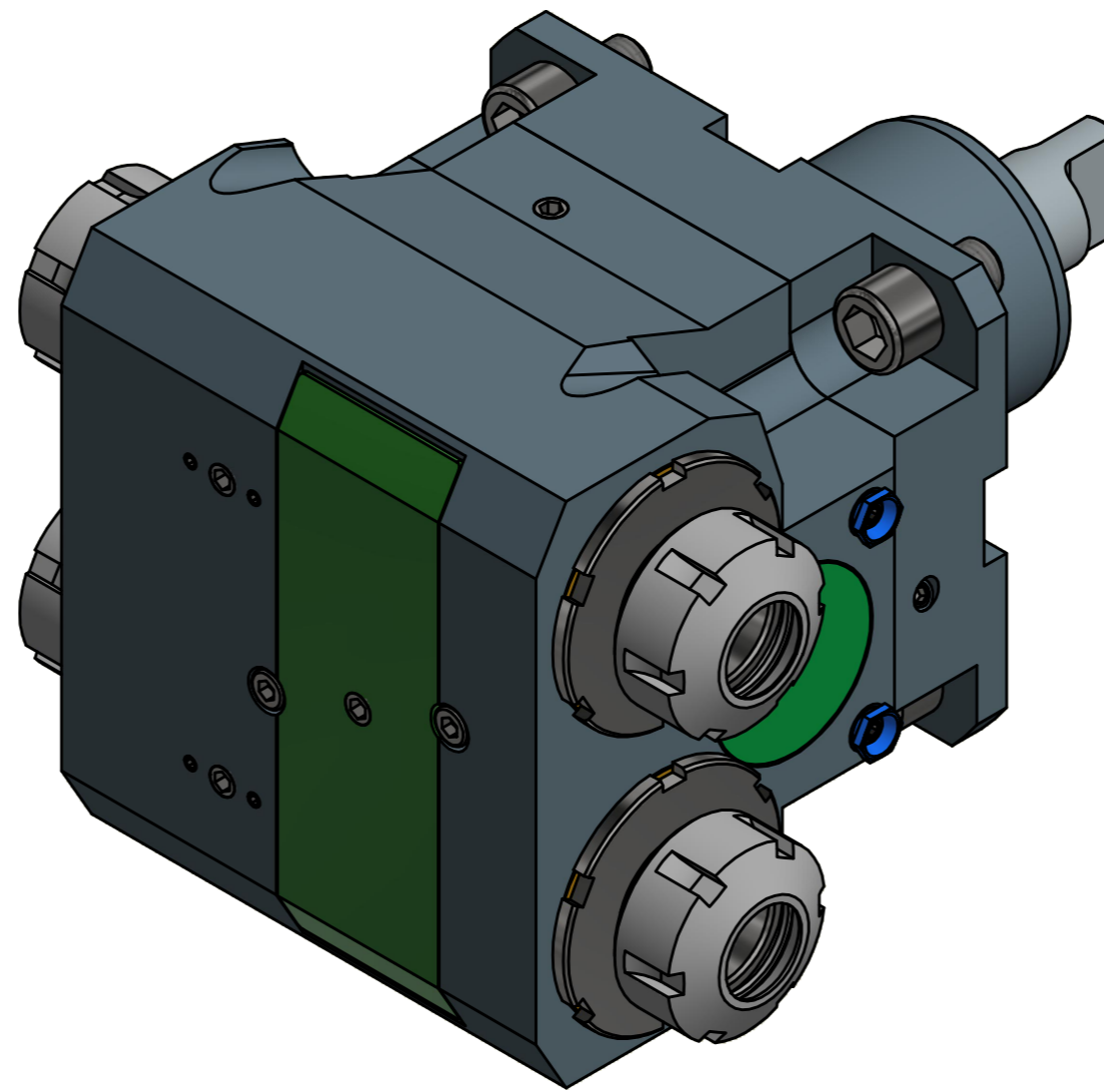

Innen- und Ausenkühlung / Inside and outside coolant supply  
 Kühlmittelfiltrierung-50µ / coolant filtration-50µ

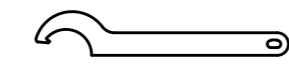

Hakenschlüssel  
 mit Nase  
 Hook wrench with  
 nose end  
 DIN1810 A 58x62



Spannzangenschlüssel  
 Clamping wrench  
 225

Copyright EWS Tool Technologies  
 Weitergabe und Vervielfältigung dieser Unterlage,  
 Verwertung und Mitteilung ihres Inhalts nicht  
 gestattet, soweit nicht ausdrücklich zugestanden.  
 Zuwiderhandlungen verpflichten zu Schadenersatz.

Bemerkung - Note	Technische Daten - technical data
Für Trockenlauf geeignet! Use without coolant fluid allowed!	Weight = 13,730 [kg] Torque max. (M1/M2) = 50 / 25 P25   25   25 Speed max. (n1/n2) = 6000 / 6000   6000   6000 Gear ratio (i)=n1:n2 = 60:90   1/1   1:1 Pressure (pmax) = 70 [bar]

Benennung - Title
<b>Radial Bohr und Fräskopf</b> <b>Radial drilling and milling head</b>

<b>EWS</b> EWS Weigle GmbH & Co. KG Maybachstr. 1 D-73066 Uhingen www.ews-tools.de	Technische Änderungen vorbehalten! Subject to technical modifications! IDENT: DEWS096934	REV: -/C MNR. 209190
Nr. - No. 60.6025QYNLIKDTK70X100		

