

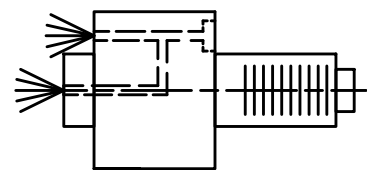

Ceramic Seal

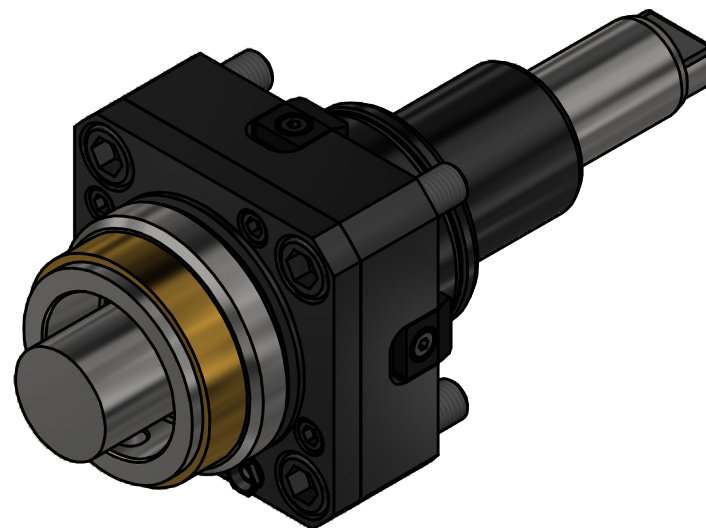

Tech Details

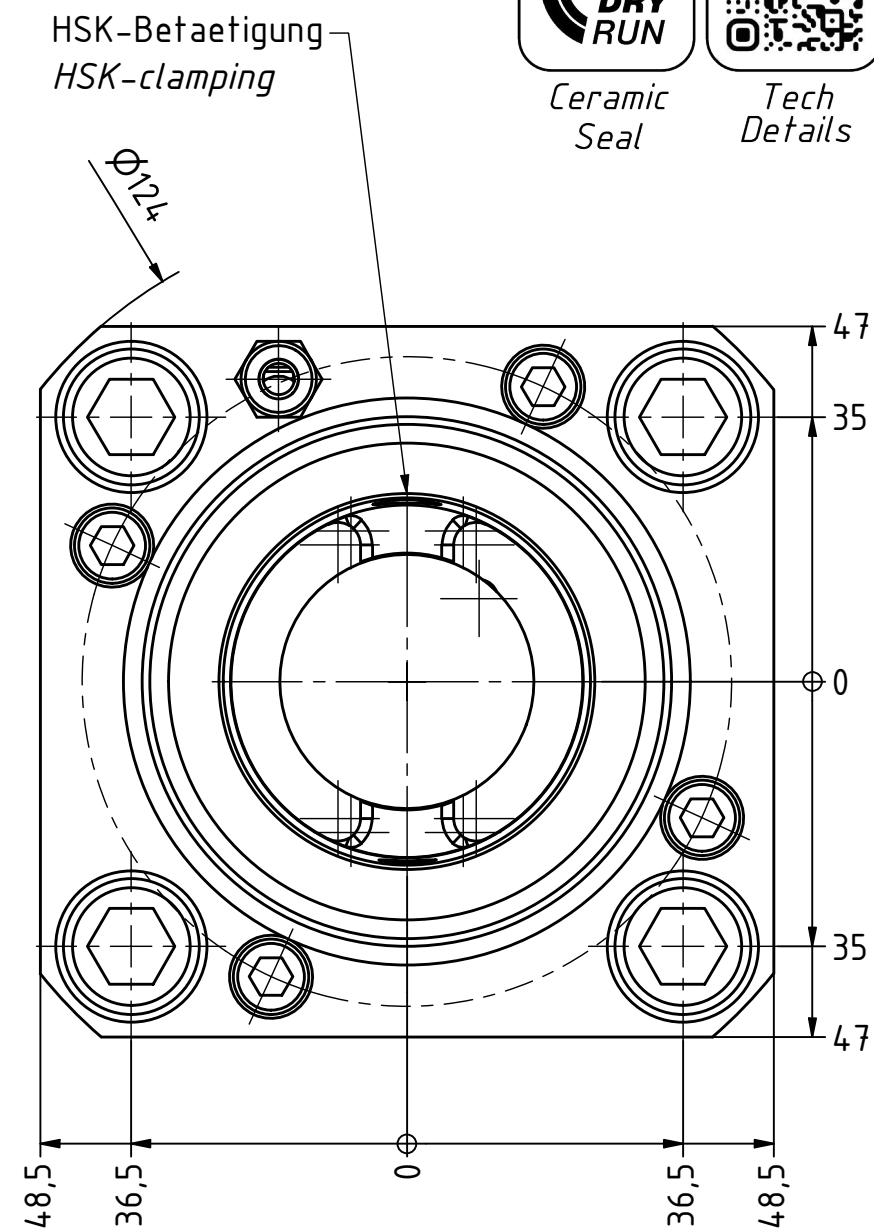
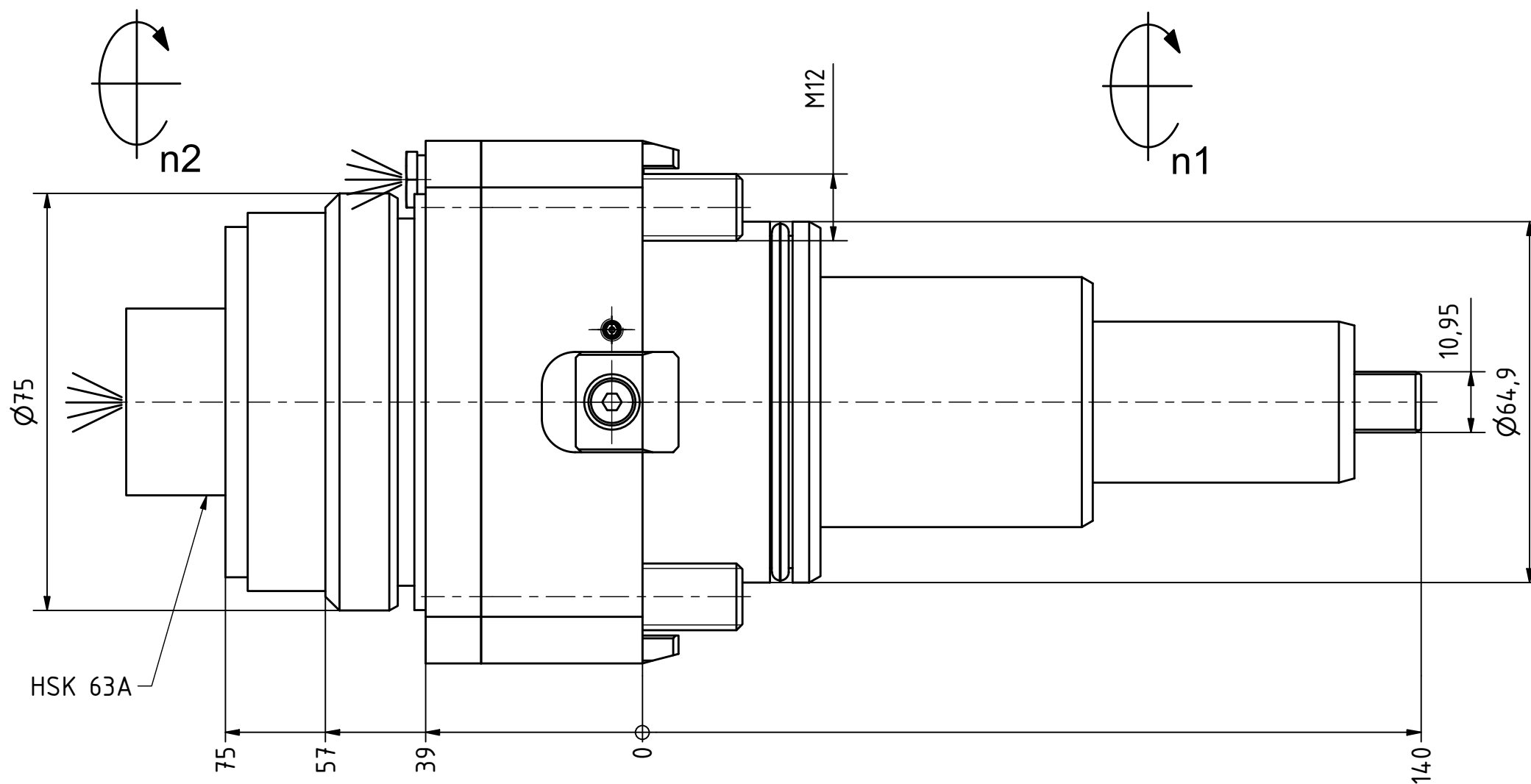

Innen- und Aussenkuehlung / Inside and outside coolant supply
Kuehlmittelfiltrierung+50µ / coolant filtration+50µ

Copyright **EWS Tool Technologies**
Weitergabe und Vervielfaeltigung dieser Unterlage,
Verwertung und Mitteilung ihres Inhalts nicht
gestattet, soweit nicht ausdrecklich zugestanden.
Zuwiderhandlungen verpflichten zu Schadenersatz.

Bemerkung - Note

Für Trockenlauf geeignet!
Use without coolant fluid allowed!

Technische Daten - technical data

Weight = 4.899 [kg]
Torque max. (M1/M2) = 63 / 63 [Nm]
Speed max. (n1/n2) = 6000 / 6000 [1/min]
Gear ratio (i)=n1:n2 = 1:1
Pressure (pmax) = 70 [bar]

Benennung - Title

Axial Bohr und Fräskopf
Axial drilling and milling head



EWS Weigele GmbH & Co. KG
Maybachstr. 1
D-73066 UHINGEN
www.ews-tools.de

Technische Aenderungen vorbehalten!
Subject to technical modifications!

IDENT: DEWS152565



REV: -/B

Nr. - No.

40.65HSK63VT4IKD

MNR.

216704

