

Kühlmittelezufuhr  
coolant supply

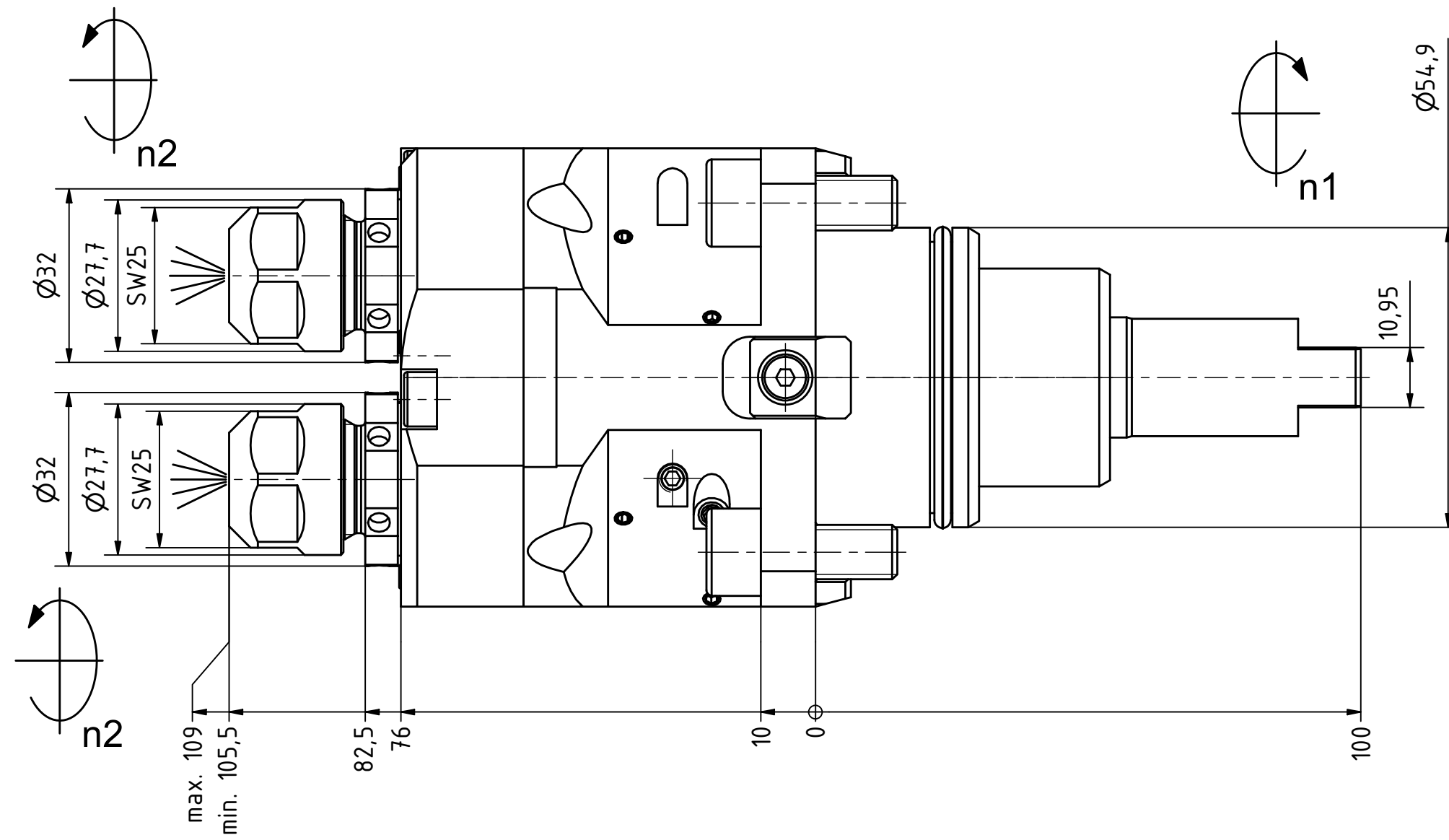

Spannzange / Collet ER16 DIN6499  
Spannbereich / Clamping range: 1,0 - 10,0

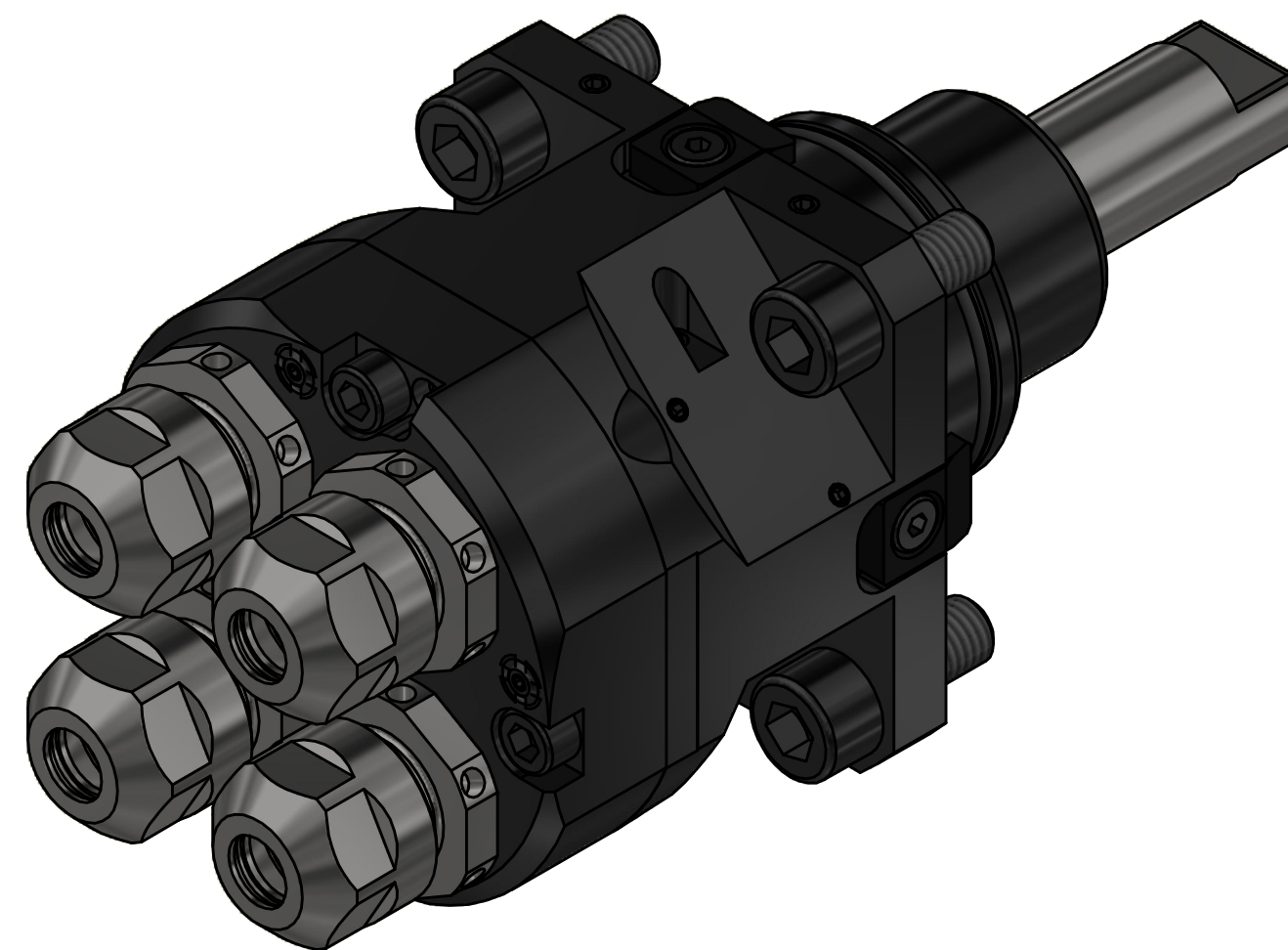
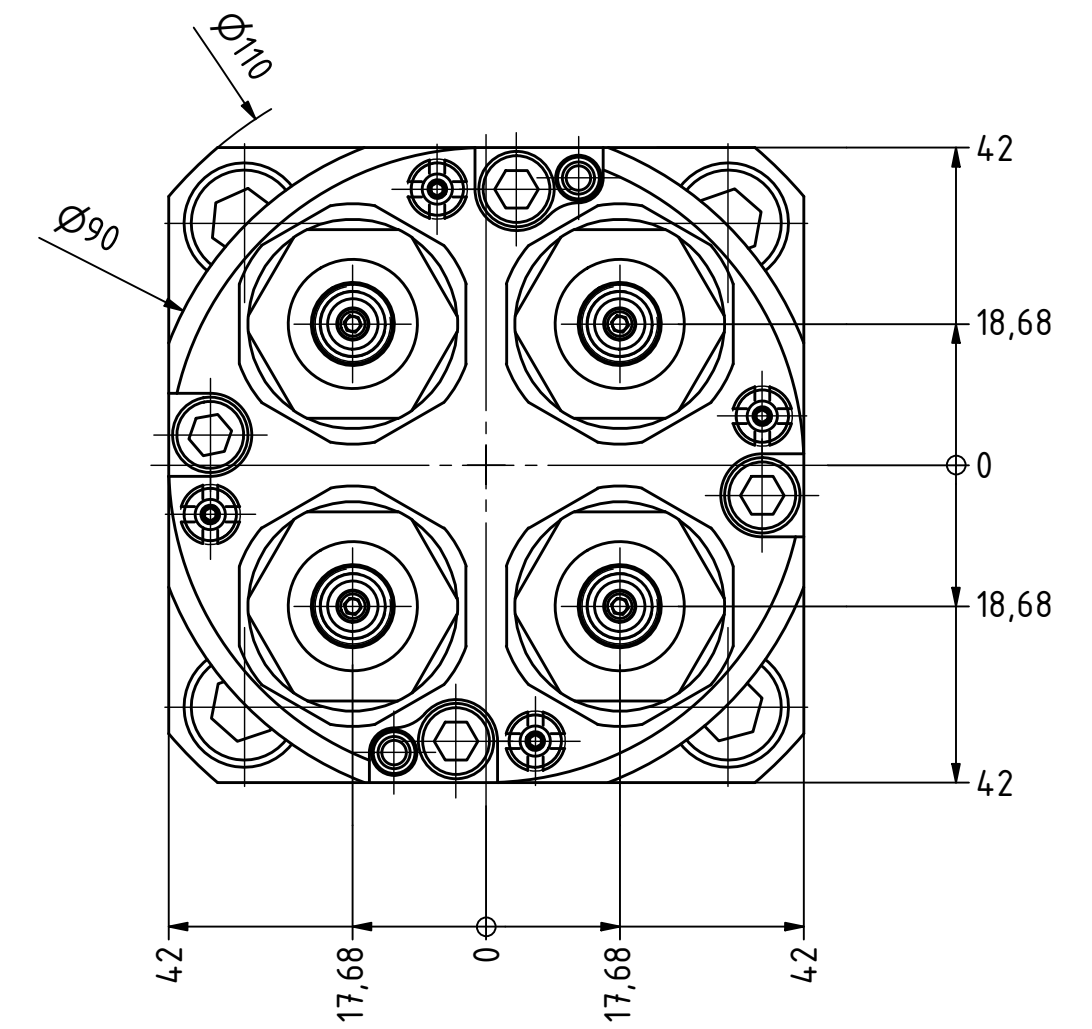

MMS - max. 10 bar  
MQL - max. 10 bar

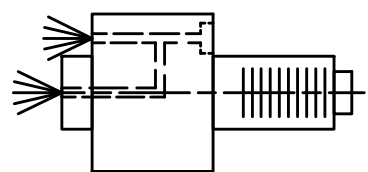

Innen- und Aussenkuehlung / Inside and outside coolant supply  
Kuehlmittelfiltrierung-50µ / coolant filtration-50µ

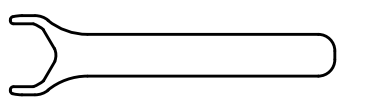

Sonderschlüssel SW30  
special key SW30  
219656 - AZS-SW30 xx

Copyright **EWS Tool Technologies**  
Weitergabe und Vervielfaeltigung dieser Unterlage,  
Verwertung und Mitteilung ihres Inhalts nicht  
gestattet, soweit nicht ausdrecklich zugestanden.  
Zuwoerhandlungen verpflichten zu Schadenersatz.

<p>Bemerkung - Note Für Trockenlauf geeignet! Use without coolant fluid allowed!</p>	<p>Technische Daten - technical data Weight = 5,357 [kg] Torque max. (M1/M2) = 16 / 8 each Sp. [Nm] Speed max. (n1/n2) = 6000 / 12000 each Sp. [1/min] Gear ratio (i)=n1:n2 = 1:2 each Sp. Pressure (pmax) = 10 MMS [bar]</p>	<p>Benennung - Title <b>Axial Bohr und Fräskopf</b> <b>Axial drilling and milling head</b></p>	<p><b>EWS</b> Tool Technologies EWS Weigle GmbH &amp; Co. KG Maybachstr. 1 D-73066 Uhlingen www.ews-tools.de</p>	<p>Technische Aenderungen vorbehalten! Subject to technical modifications! IDENT: DEWS118351 REV: -/E</p>	<p>Nr. - No. 40.5516QVL4IKDMMS11TK51.44-RF-S4 209485</p> <p><b>QR</b></p>
--	---	--	--	---	---