

Fraeserwelle austauschbar
Spindle removable

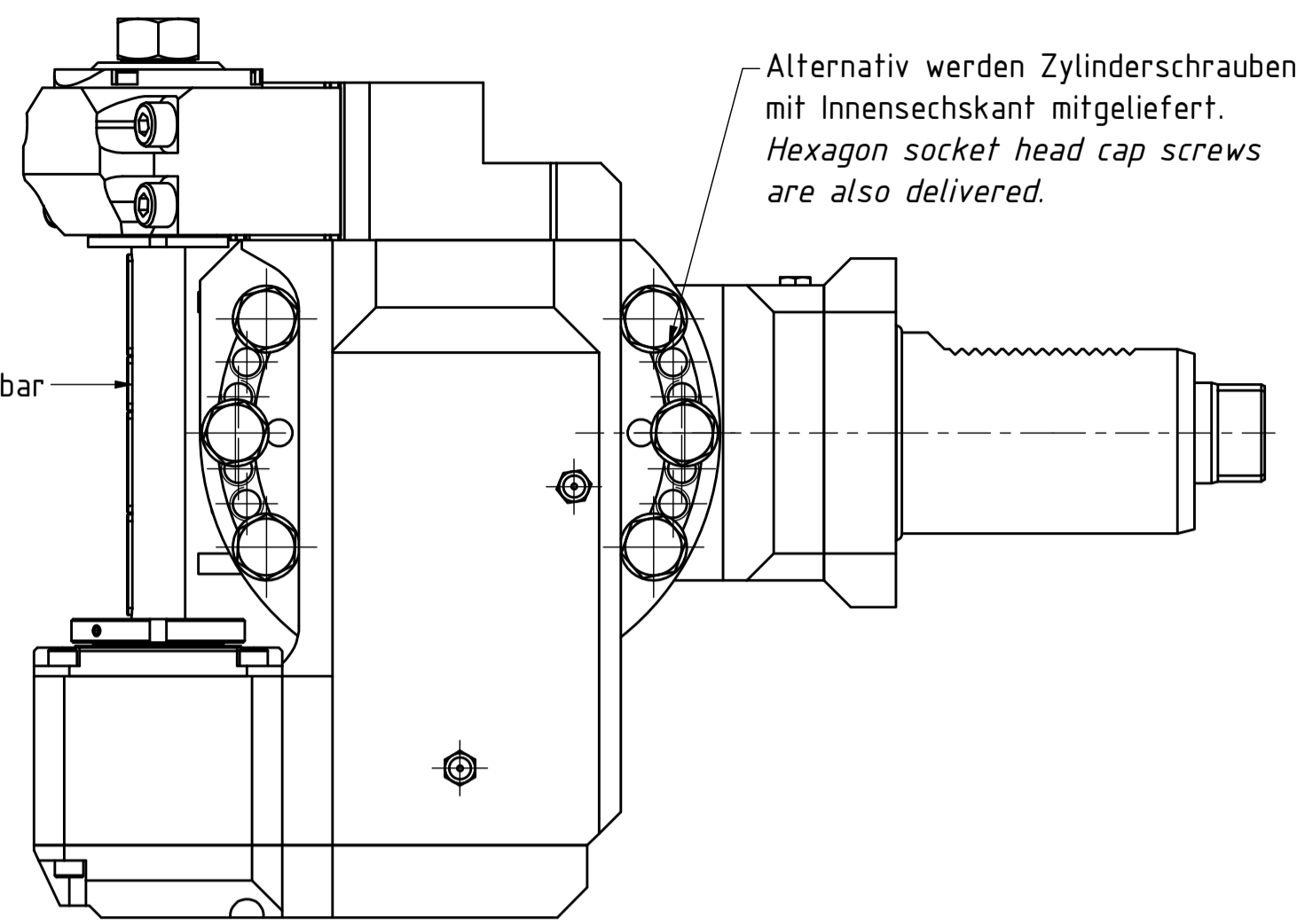

Alternativ werden Zylinderschrauben mit Innensechskant mitgeliefert.
Hexagon socket head cap screws are also delivered.

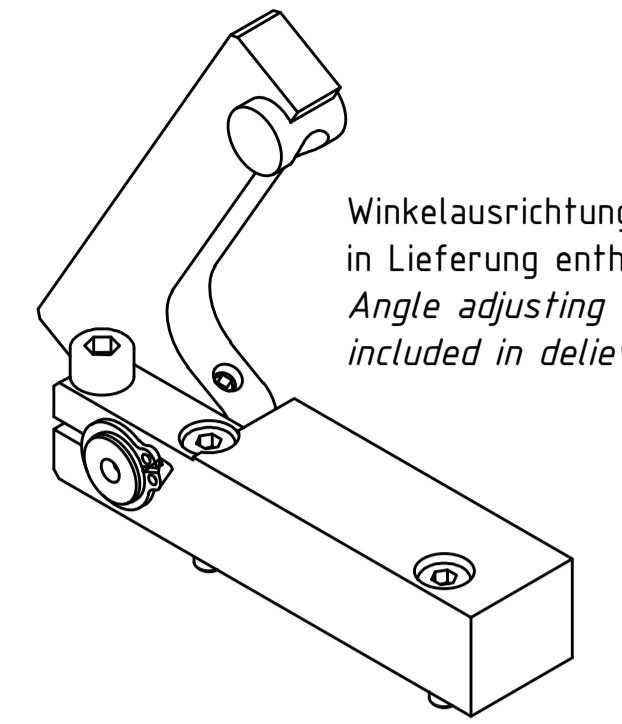

Winkelausrichtung & CD-ROM in Lieferung enthalten!
Angle adjusting & CD-ROM included in delivery!

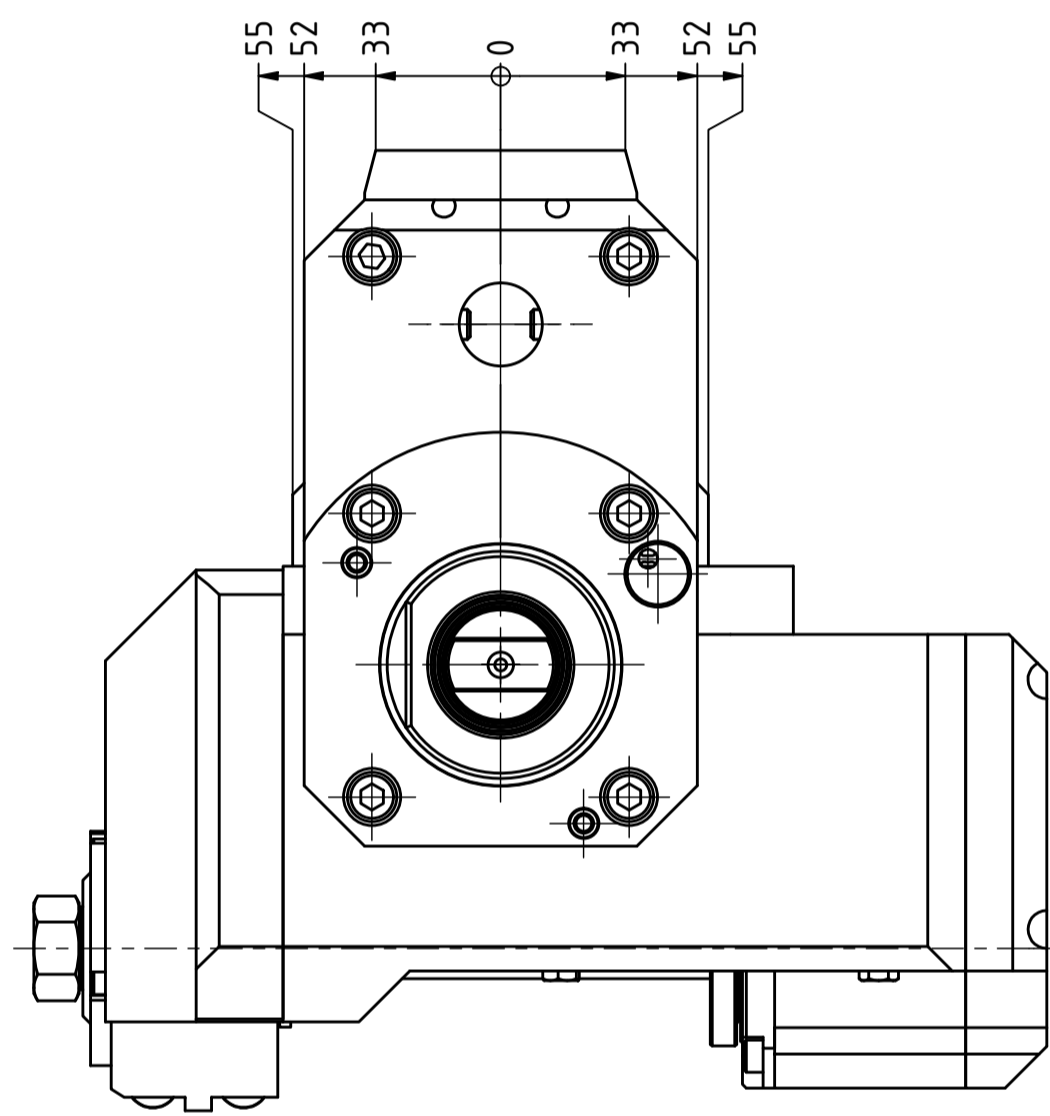

Gewindebohrungen für Winkelausrichtung.
Thread holes for angle adjusting.

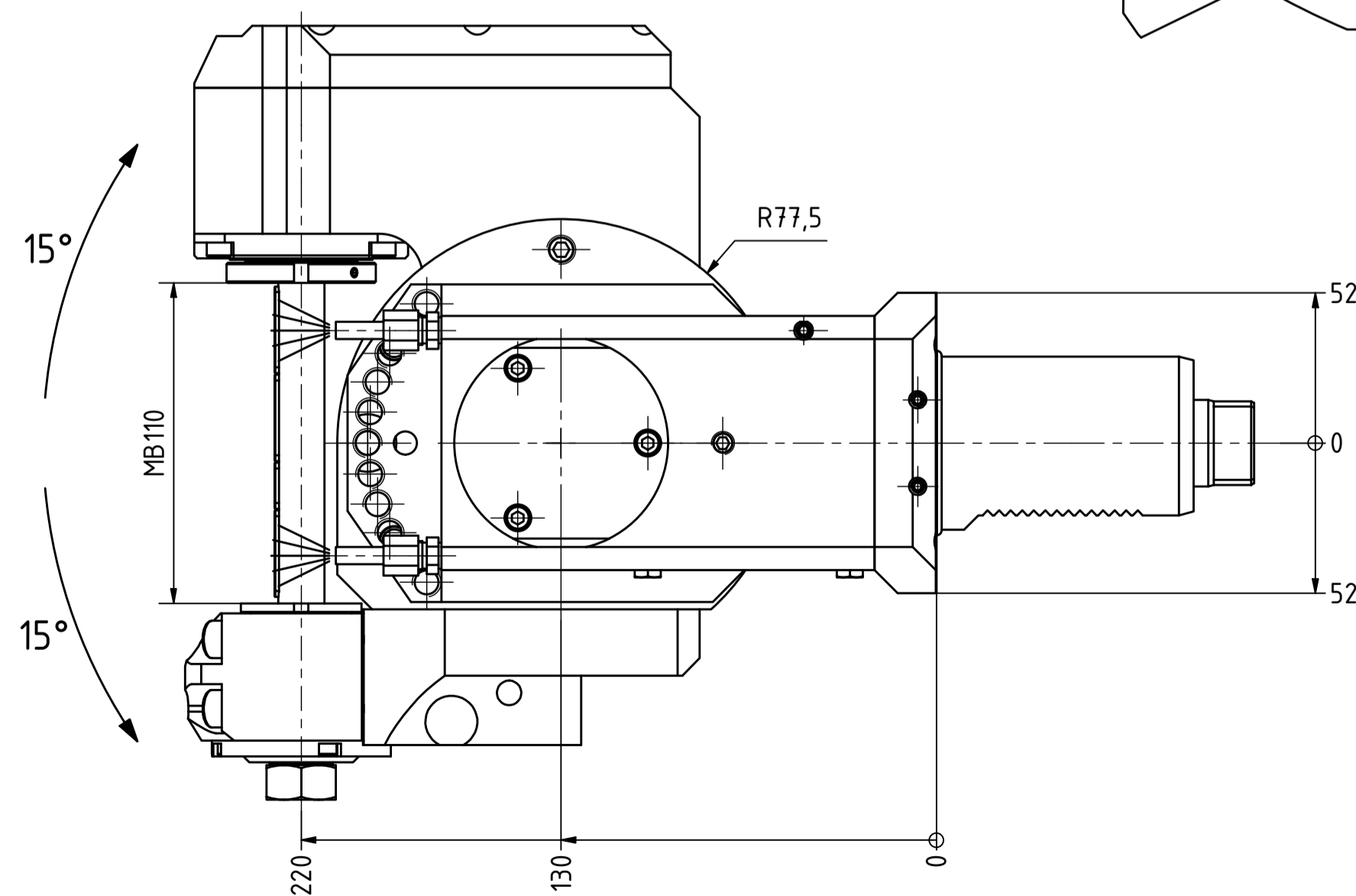
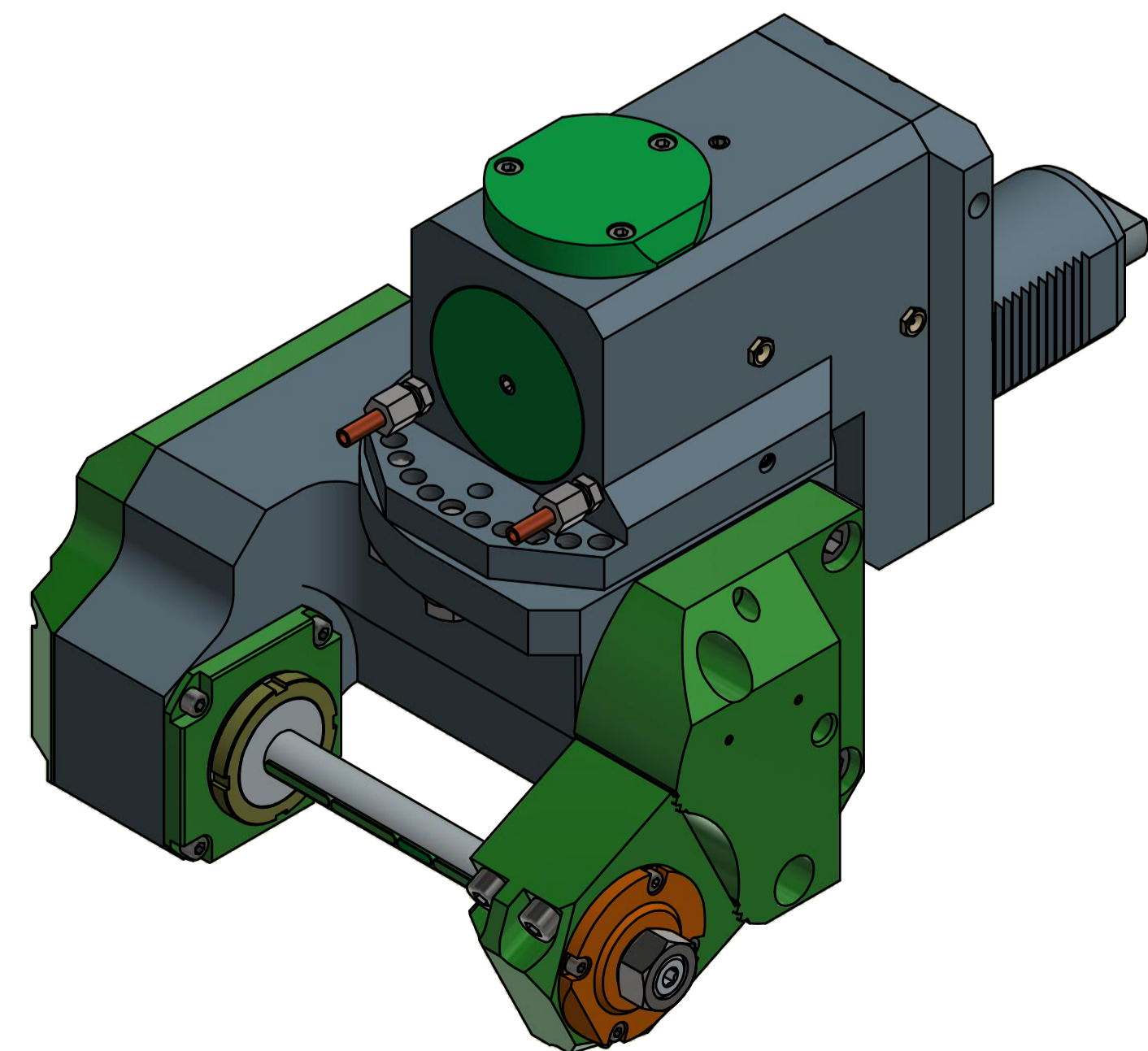
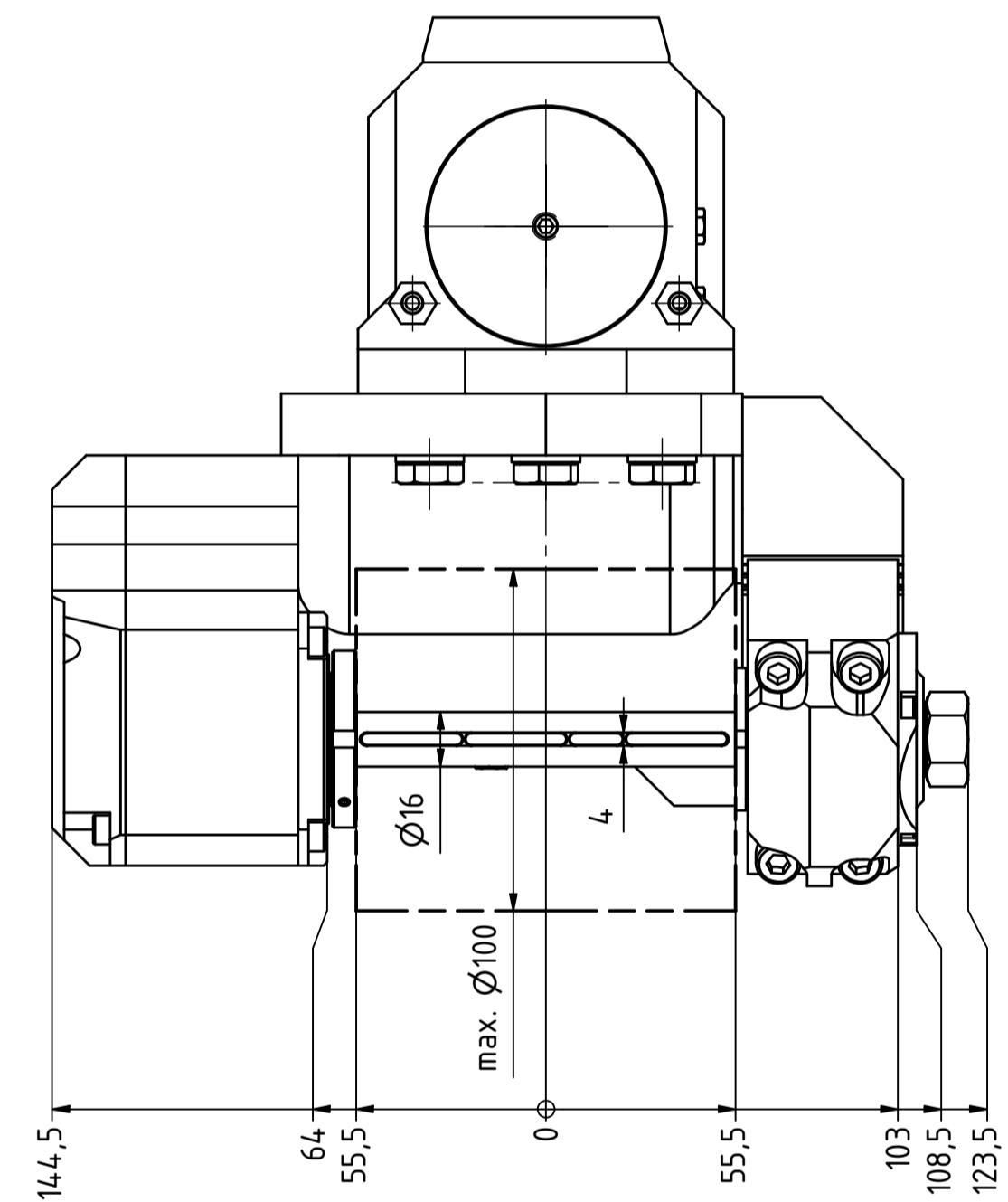
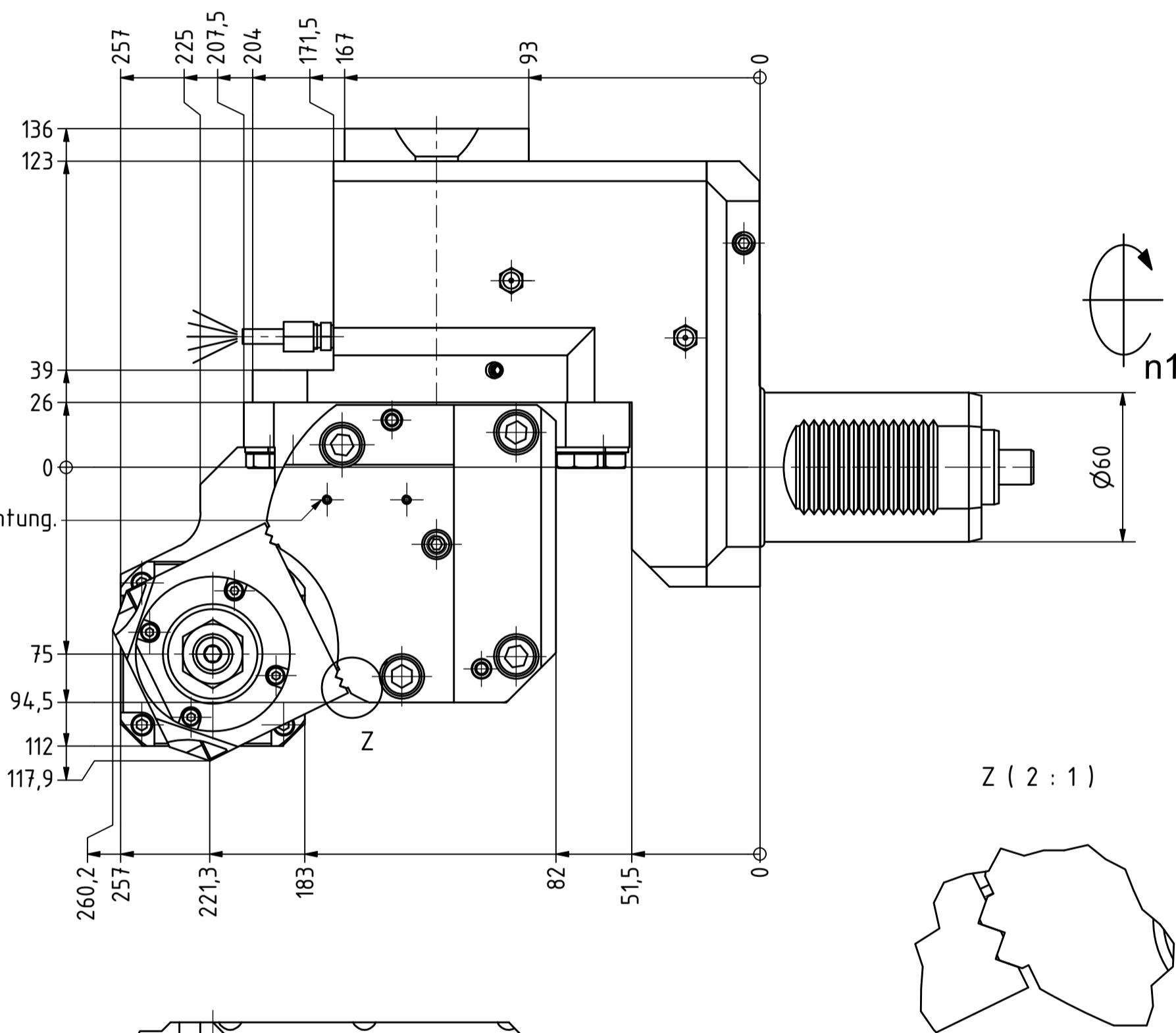
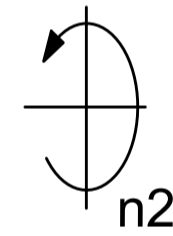

Gewicht: 33 kg Beide Nachbarstationen nicht verwendbar!
Weight: 33 kg Both neighbour stations are not useable!

Ansichten 1:2

Bezeichnung - Note
mit Kegelrollenlagern
with taper roller bearings

Technische Daten - Technical data
Weight = 33.657 [kg]
Torque max. (M1/M2) = 80 / 160 [Nm]
Speed max. (n1/n2) = 4.000 / 2000 [1/min]
Gear ratio (i)=n1:n2 = 2:1

Bezeichnung - Title
Radial Scheibenfräserkopf versetzt
Saw milling spindle offset

	<small>EWS Werkzeug GmbH & Co. KG Hauptstr. 1 62700 Löhren www.ews-tool.de</small>	<small>Technische Änderungen vorbehalten! Subject to technical modifications!</small>	
	<small>IDENT: DEWS087123</small>	<small>REV: -/A</small>	QR
<small>84.60161809RI2TKWZ70MB110</small>		<small>216500</small>	

Copyright EWS Tool Technologies
Weitergabe und Vervielfältigung dieser Unterlage,
Verwertung und Mitteilung ihres Inhalts nicht
gestattet, soweit nicht ausdrücklich zugestanden.
Zu widerhandlungen verpflichten zu Schadenersatz.