

Bitte überprüfen Sie, ob der Werkzeughalter auf ihrem Revolver im Maschinenraum ohne Kollision durchschwenken kann.
 Please check the work space of the machine for interferences with the tool holder, especially the swiveling diameter.

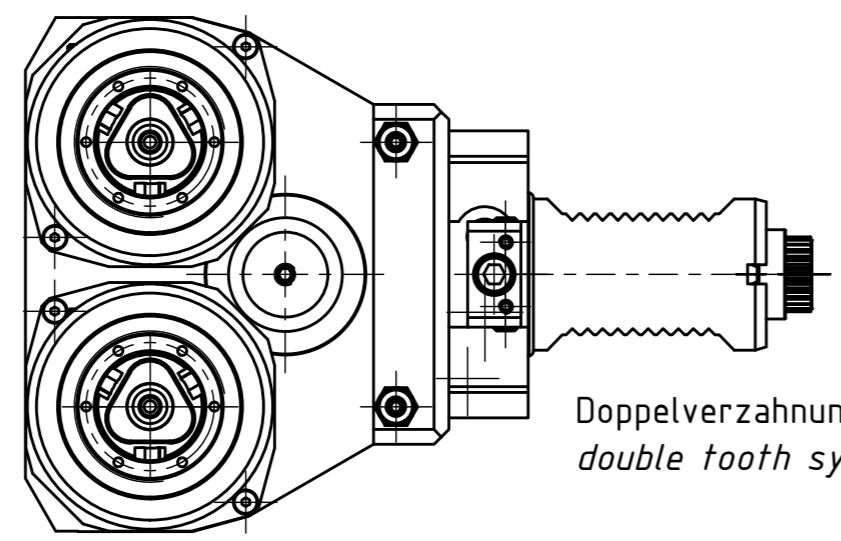

Doppelverzahnung Lizenz Traub
 double tooth system licence Traub

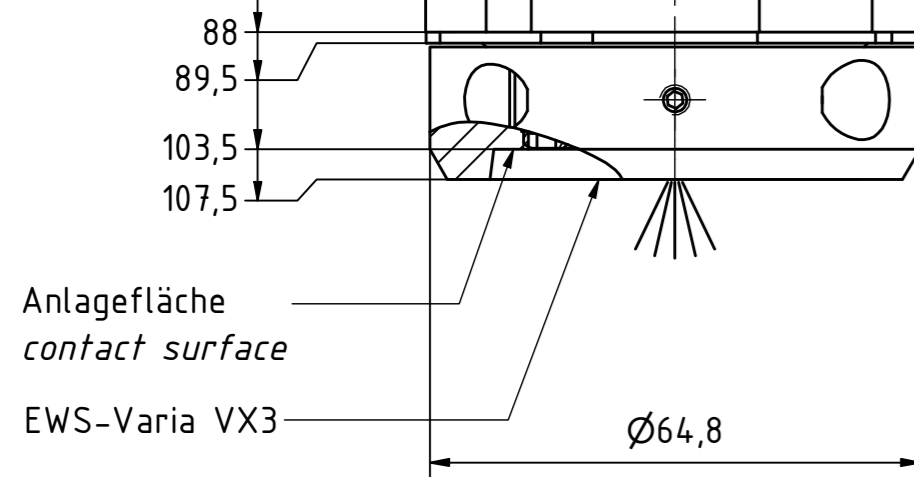
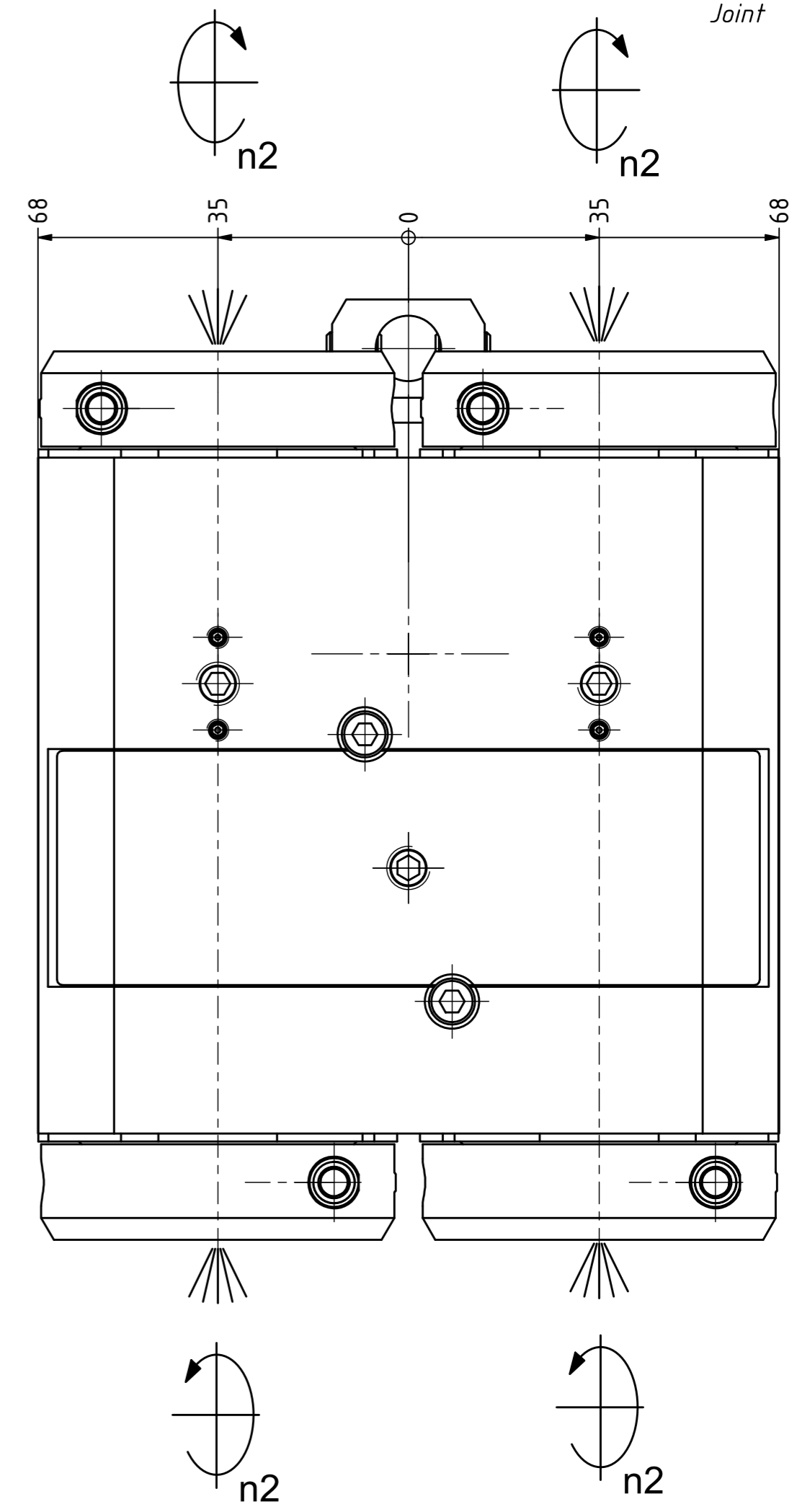
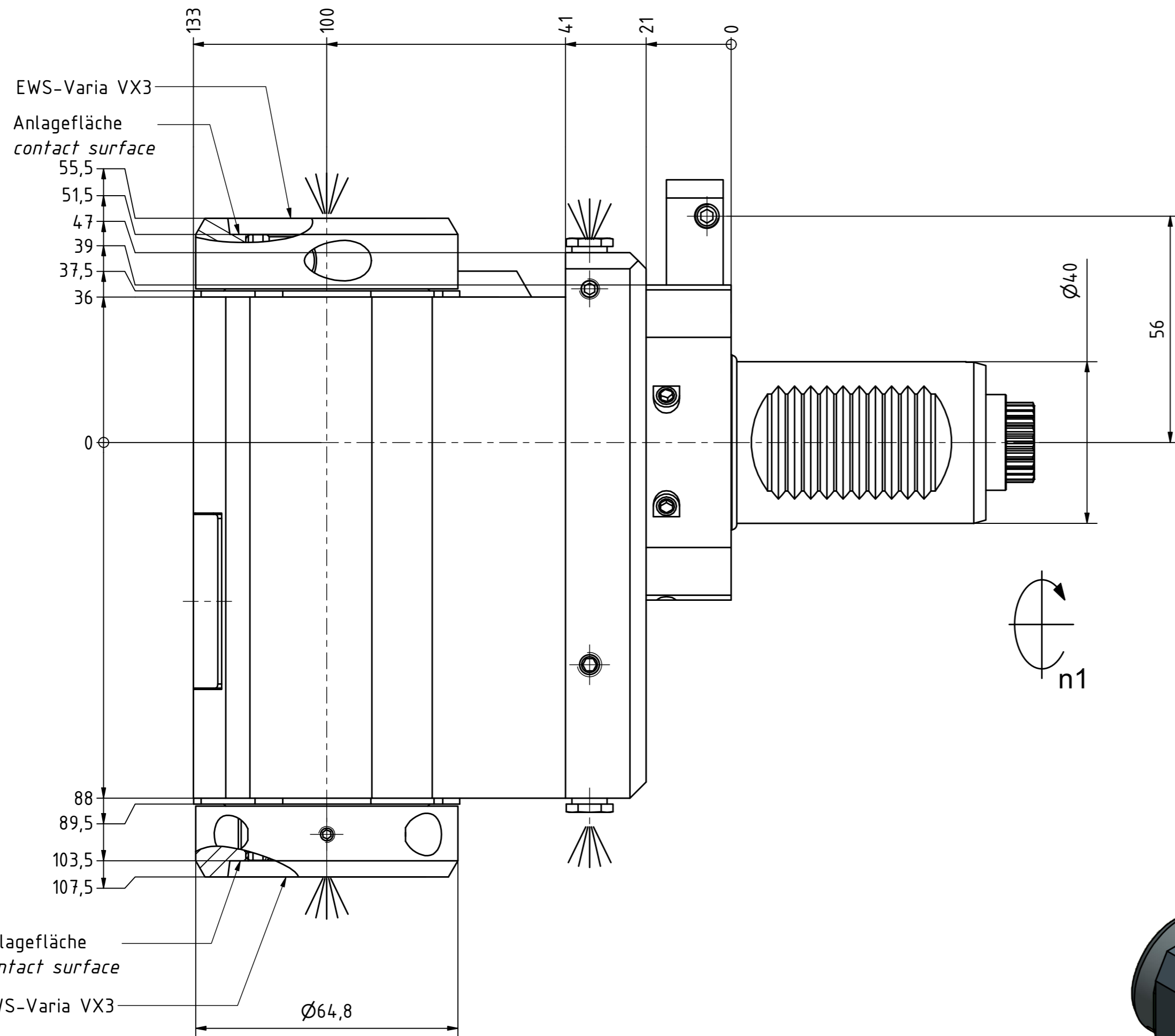
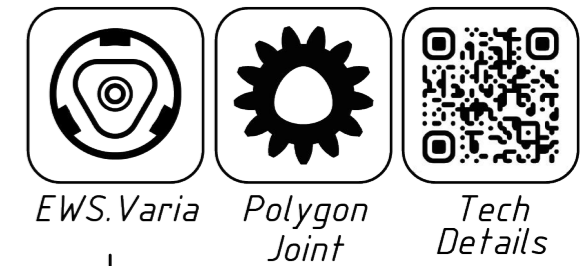
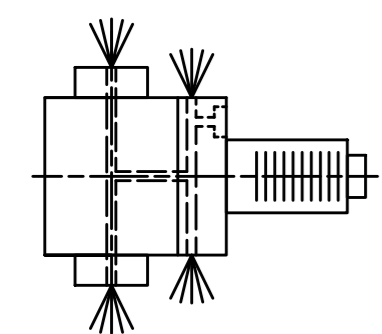
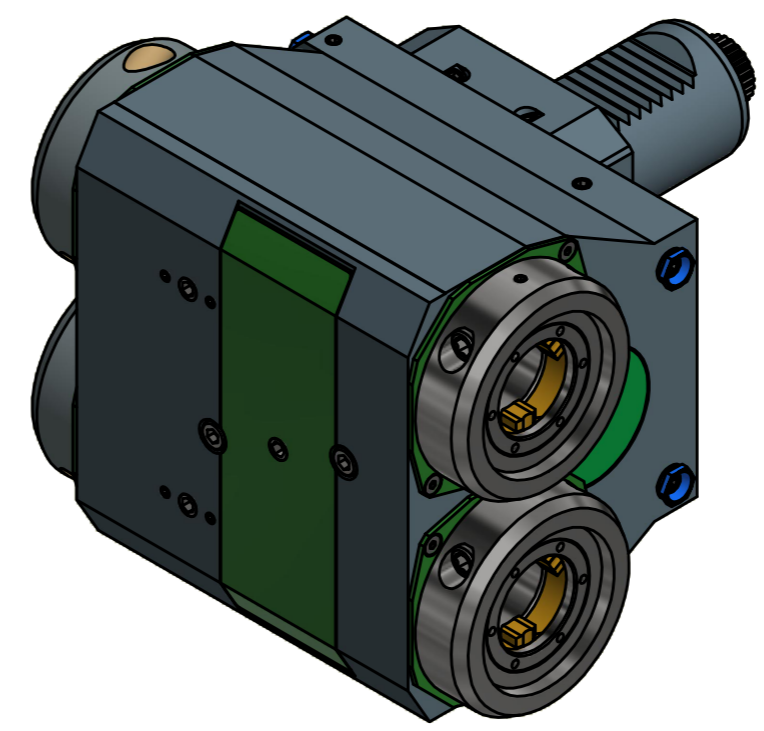

Innen- und Aussenkuehlung / Inside and outside coolant supply
 Kuehlmittefiltrierung=50µ / coolant filtration=50µ

Bemerkung - Note
 Für Trockenlauf geeignet!
 Use without coolant fluid allowed!

Technische Daten - technical data	
Weight	= 12.765 [kg]
Torque max. (M1/M2)	= 50/25/25/25 [Nm]
Speed max. (n1/n2)	= 6000/6000/6000/6000 [1/min]
Gear ratio (i)	= n1:n2 = 1:1
Pressure (pmax)	= 70 [bar]

Benennung - Title
Radial Bohr und Fräskopf
Radial drilling and milling head

EWS Weigle GmbH & Co. KG Maybachstr. 1 D-73066 Uhlingen www.ews-tool.de	Technische Änderungen vorbehalten! Subject to technical modifications! IDENT: DEWS139962	MNR. REV: -/C
	Nr. - No. 60.40VX3QYCTXRLIKDTK70	MNR. 208908

Copyright EWS Tool Technologies
 Weitergabe und Vervielfältigung dieser Unterlage, Verwertung und Mitteilung ihres Inhalts nicht gestattet, soweit nicht ausdrücklich zugestanden. Zuwiderhandlungen verpflichten zu Schadenersatz.

