

Spannzange / collet ER25 DIN6499  
 Spannbereich / clamping range: 1,0 - 16,0

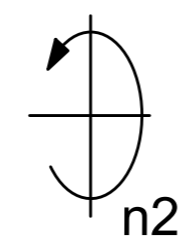

Z (2:1)

Ausrichtklotz ist per Exzenter einstellbar  
 The block is adjustable via eccentric

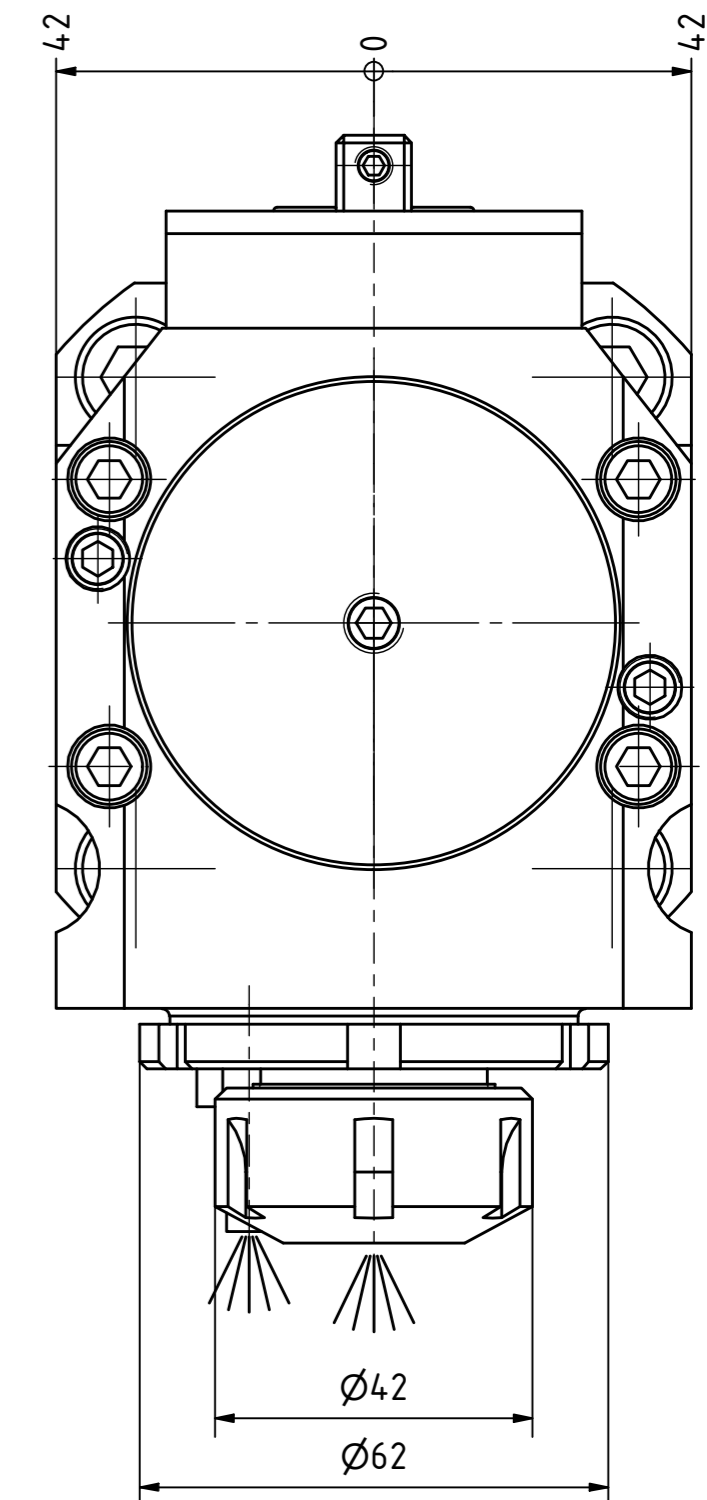
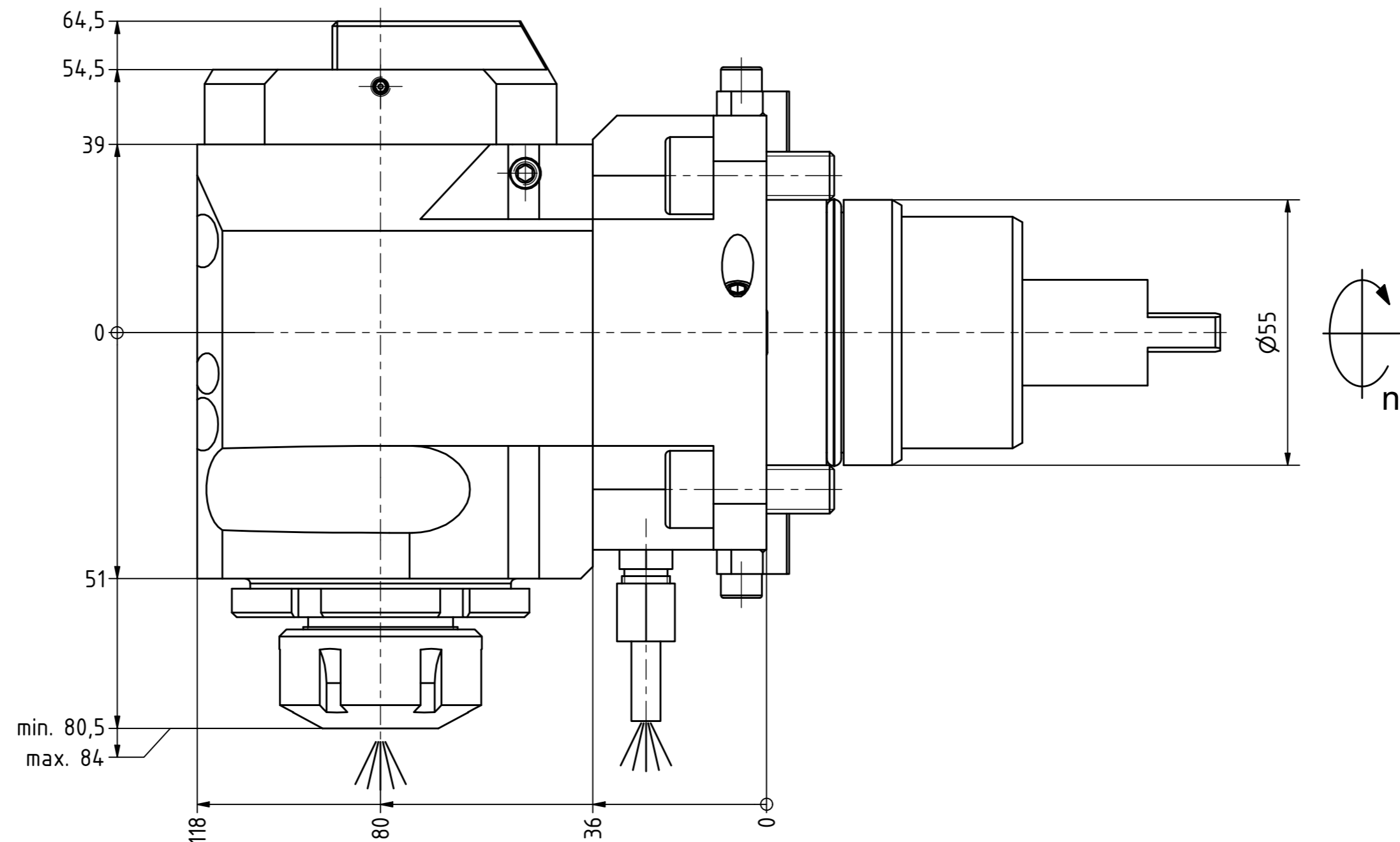
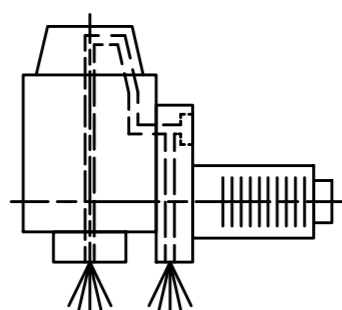
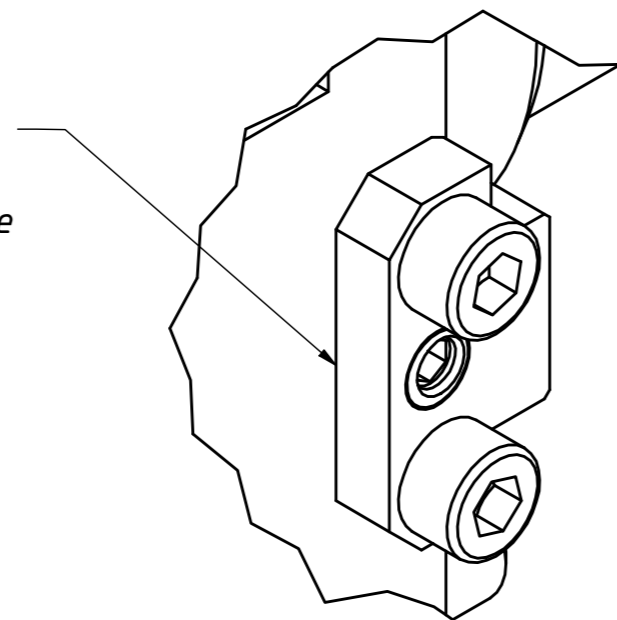

Innen- und Aussenkuehlung / Inside and outside coolant supply  
 Kein Trockenlauf / No dry run  
 Kuehlmittelfiltrierung <math>50\mu</math> / coolant filtration <math>50\mu</math>

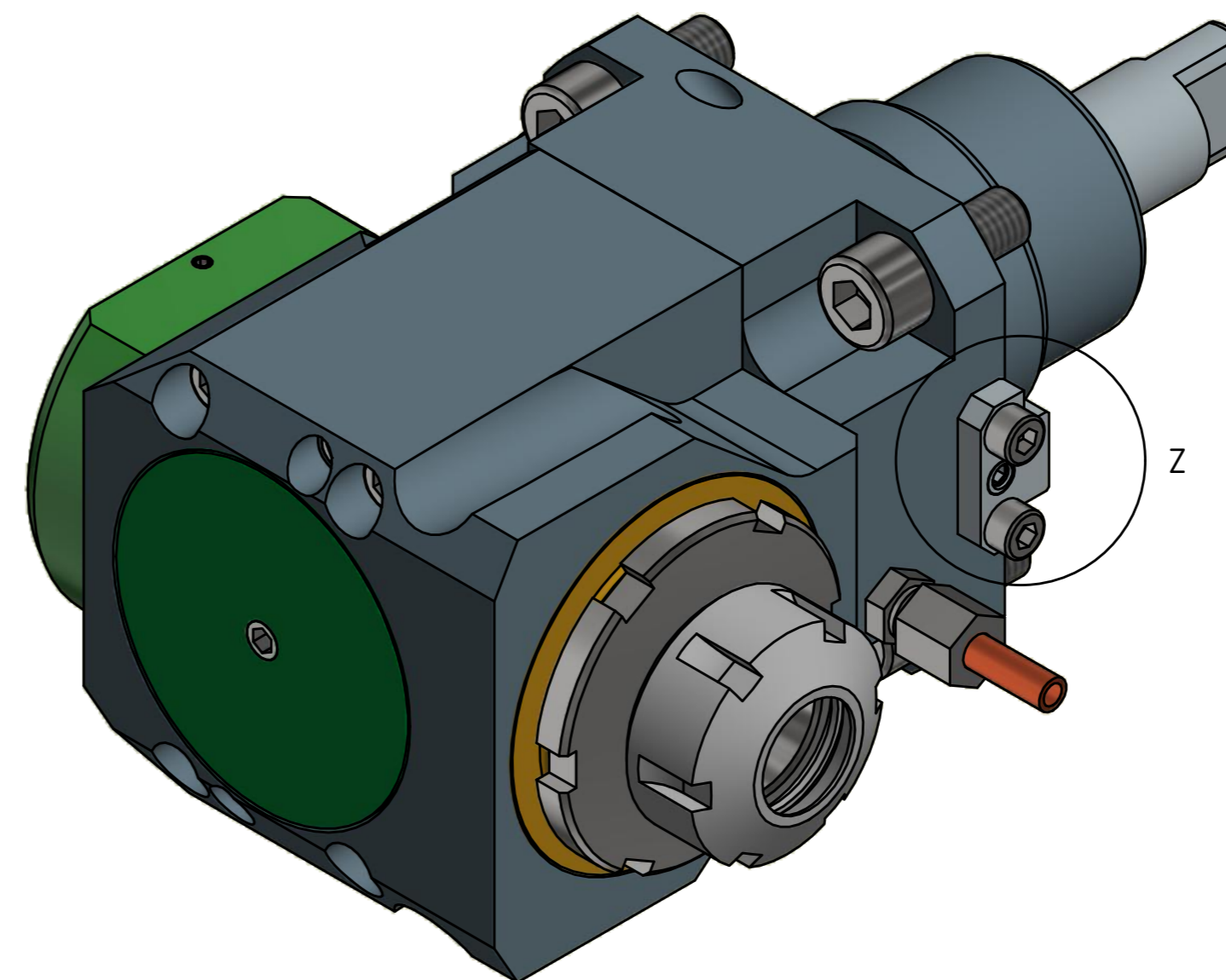

Spannzangenschlüssel  
 Clamping wrench  
 225

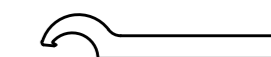

Hakenschlüssel  
 mit Nase  
 Hook wrench with  
 nose end  
 DIN1810 A 58x62

Copyright **EWS Tool Technologies**  
 Weitergabe und Vervielfaeltigung dieser Unterlage,  
 Verwertung und Mitteilung ihres Inhalts nicht  
 gestattet, soweit nicht ausdrecklich zugestanden.  
 Zuwiderhandlungen verpflichten zu Schadenersatz.

Bemerkung - Note  
 Nicht ohne Kuehlmittel betreiben!  
 Not for use without coolant-fluid!

Technische Daten - technical data  
 Weight = 6,458 [kg]  
 Torque max. (M1/M2) = 50 / 25 [Nm]  
 Speed max. (n1/n2) = 6000 / 12000 [1/min]  
 Gear ratio (i)=n1:n2 = 1:2  
 Pressure (pmax) = 70 [bar]

Benennung - Title  
 Radial Bohr und Fräskopf  
 Radial drilling and milling head



Nr. - No.  
 60.5525BIG1809IK11X80#01

Technische Aenderungen vorbehalten!  
 Subject to technical modifications!  
 IDENT: DEWS078353

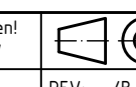

REV: -/B  
 MNR.  
 209124

