

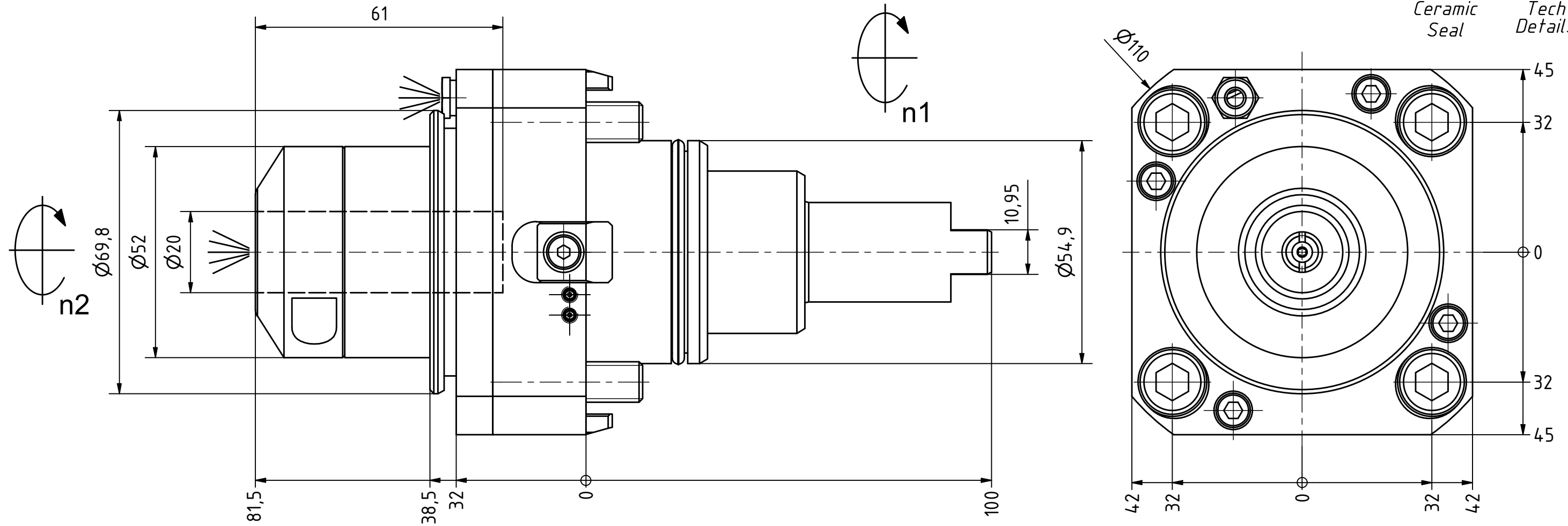

Ceramic Seal

Tech Details



Hydrodehnfutter / hydraulic chuck NBC-20/25-52 ECO

Hülsen / collets 28.20xxHYDxx

XX (Ø)	3	4	5	6	7	8	9	10	12	14	16
	1/8	3/16	1/4	5/16	3/8	7/16	1/2	9/16	5/8		

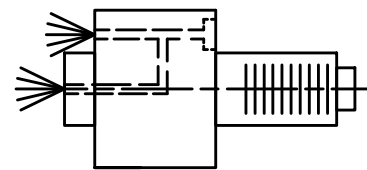

Innen- und Aussenkuehlung / Inside and outside coolant supply
Kuehlmittelfiltrierung<50µ / coolant filtration<50µ

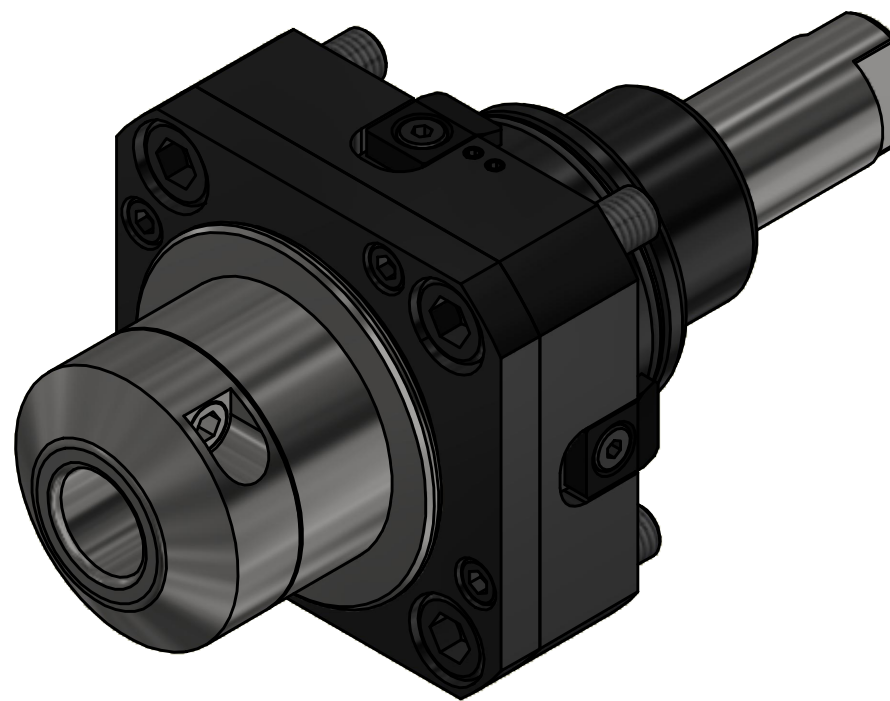

Copyright **EWS Tool Technologies**
Weitergabe und Vervielfaeltigung dieser Unterlage,
Verwertung und Mitteilung ihres Inhalts nicht
gestattet, soweit nicht ausdrecklich zugestanden.
Zuwiderhandlungen verpflichten zu Schadenersatz.

Bemerkung - Note
Für Trockenlauf geeignet!
Use without coolant fluid allowed!

Technische Daten - technical data	
Weight	= 3.251 [kg]
Torque max. (M1/M2)	= 50 / 50 [Nm]
Speed max. (n1/n2)	= 6000 / 6000 [1/min]
Gear ratio (i)=n1:n2	= 1:1
Pressure (pmax)	= 70 [bar]

Benennung - Title
Axial Bohr und Fräskopf
Axial drilling and milling head



Technische Aenderungen vorbehalten!
Subject to technical modifications!
IDENT: DEWS228792



REV: -/C

Nr. - No.
40.5520HYDV4IKC-S01

MNR.
216096

