

Spannzange / collet ER32 DIN6499
Spannbereich / clamping range: 2,0 - 20,0

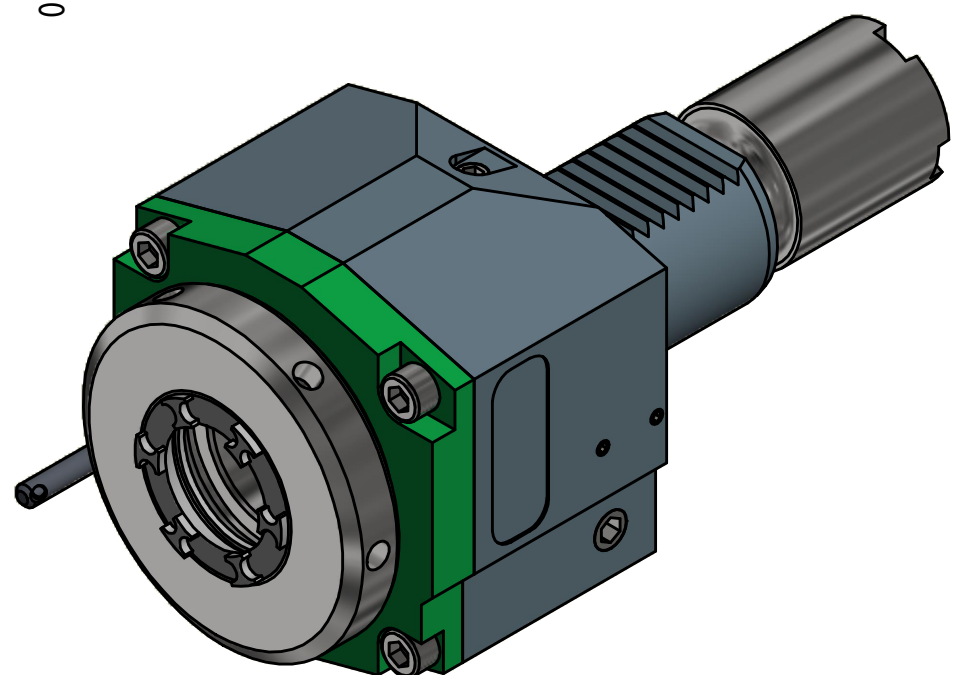
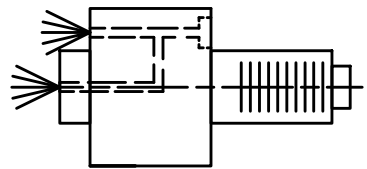

Spannzangenschlüssel für innenliegende Mutter
Clamping wrench for internal collet
225AX

Hakenschlüssel mit Zapfen
Hook wrench with fixed pin
DIN1810 B 68x75

Innen- und Aussenkuehlung / Inside and outside coolant supply
Kuehlmittelfiltrierung <math>< 50\mu</math> / coolant filtration <math>< 50\mu</math>

Copyright **EWS Tool Technologies**
Weitergabe und Vervielfaeltigung dieser Unterlage, Verwertung und Mitteilung ihres Inhalts nicht gestattet, soweit nicht ausdrecklich zugestanden. Zuwiderhandlungen verpflichten zu Schadenersatz.

| | | | | | |
|---|---|---|--|---|---|
| <p>Bemerkung - Note</p> <p>Für Trockenlauf geeignet! Use without coolant fluid allowed!</p> | <p>Technische Daten - technical data</p> <p>Weight = 3.829 [kg] Torque max. (M1/M2) = 63 / 63 [Nm] Speed max. (n1/n2) = 6000 / 6000 [1/min] Gear ratio (i)=n1:n2 = 1:1 Pressure (pmax) = 70 [bar]</p> | <p>Benennung - Title</p> <p>Axial Bohr und Fräskopf Axial drilling and milling head</p> | <p>EWS Tool Technologies EWS Weigle GmbH & Co. KG Maybachstr. 1 D-73066 UHINGEN www.ews-tools.de</p> <p>Nr. - No. 40.4032LB25IKCIM</p> | <p>Technische Aenderungen vorbehalten! Subject to technical modifications!</p> <p>IDENT: DEWS134.082 REV: -/A</p> | <p>QR</p> <p>MNR. 208200</p> |
|---|---|---|--|---|---|