

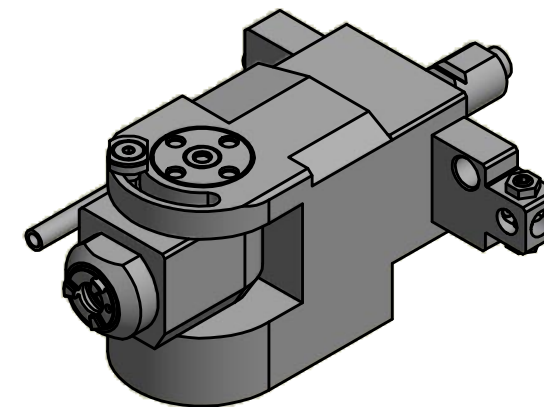

Spannzange / Collet ER11 DIN6499
 Spannbereich / Clamping range: 0,5 - 7,0

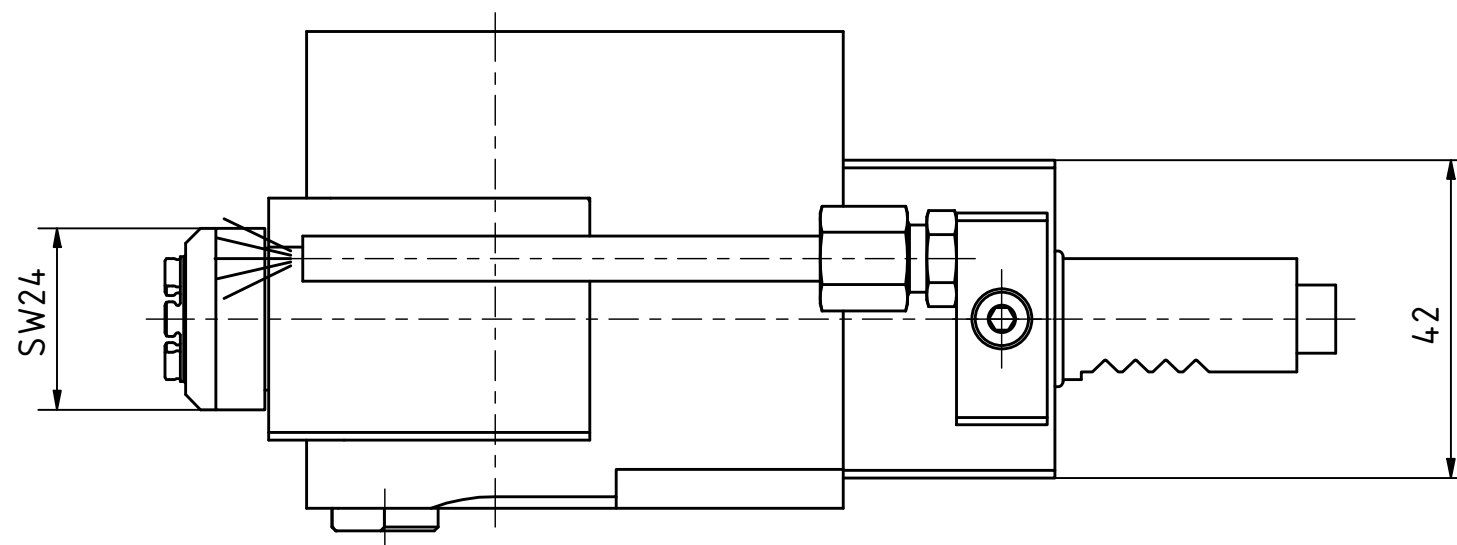

Copyright **EWS Tool Technologies**
 Weitergabe und Vervielfaeltigung dieser Unterlage,
 Verwertung und Mitteilung ihres Inhalts nicht
 gestattet, soweit nicht ausdrecklich zugestanden.
 Zuwiderhandlungen verpflichten zu Schadenersatz.

Bemerkung - Note Schwenkbereich $\pm 90^\circ$ swivel area $\pm 90^\circ$	Technische Daten - technical data Weight = [kg] Torque max. (M1/M2) = 6,3 / 6,3 [Nm] Speed max. (n1/n2) = 6000 / 6000 [1/min] Gear ratio (i)=n1:n2 = 1:1	Benennung - Title 	 EWS Weigle GmbH & Co. KG Maybachstr. 1 D-73066 Uhingen www.ews-tools.de	Technische Aenderungen vorbehalten! Subject to technical modifications! IDENT: DEWS046049 MNR. 208191	 
---	--	---------------------------------------	--	---	---