

Innen- und Aussenkuehlung / Inside and outside coolant supply
 Kuehlmittelfiltrierung<50µ / coolant filtration<50µ

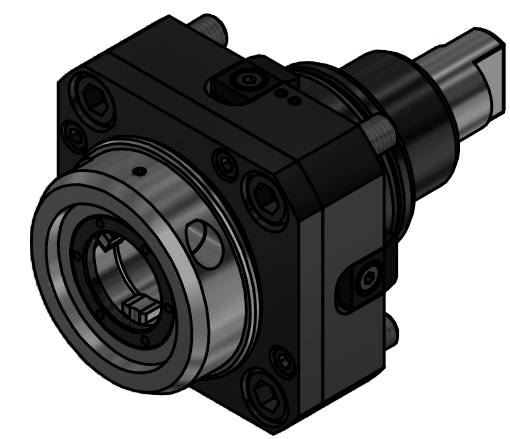

Copyright **EWS Tool Technologies**
 Weitergabe und Vervielfaeltigung dieser Unterlage,
 Verwertung und Mitteilung ihres Inhalts nicht
 gestattet, soweit nicht ausdrecklich zugestanden.
 Zuwiderhandlungen verpflichten zu Schadenersatz.

<p>Bemerkung - Note Für Trockenlauf geeignet! <i>Use without coolant fluid allowed!</i></p>	<p>Technische Daten - technical data Weight = 2.906 [kg] Torque max. (M1/M2) = 50 / 50 [Nm] Speed max. (n1/n2) = 10000 / 10000 [1/min] Gear ratio (i)=n1:n2 = 1:1 Pressure (pmax) = 70 [bar]</p>	<p>Benennung - Title Axial Bohr und Fräskopf Axial drilling and milling head</p>	<p>EWS Tool Technologies <small>EWS Weigele GmbH & Co. KG Maybachstr. 1 D-73066 Uhingen www.ews-tools.de</small></p>	<p>Technische Aenderungen vorbehalten! <i>Subject to technical modifications!</i> IDENT: DEWS233664</p>	<p> REV: -/B MNR. 224389</p>	<p>QR</p>
<p>Nr. - No. 40.55VX3VLHP2IKCHSD10</p>						