



Ceramic Seal



Tech Details

Anzugsdrehmoment 45Nm
Clamping torque 45Nm

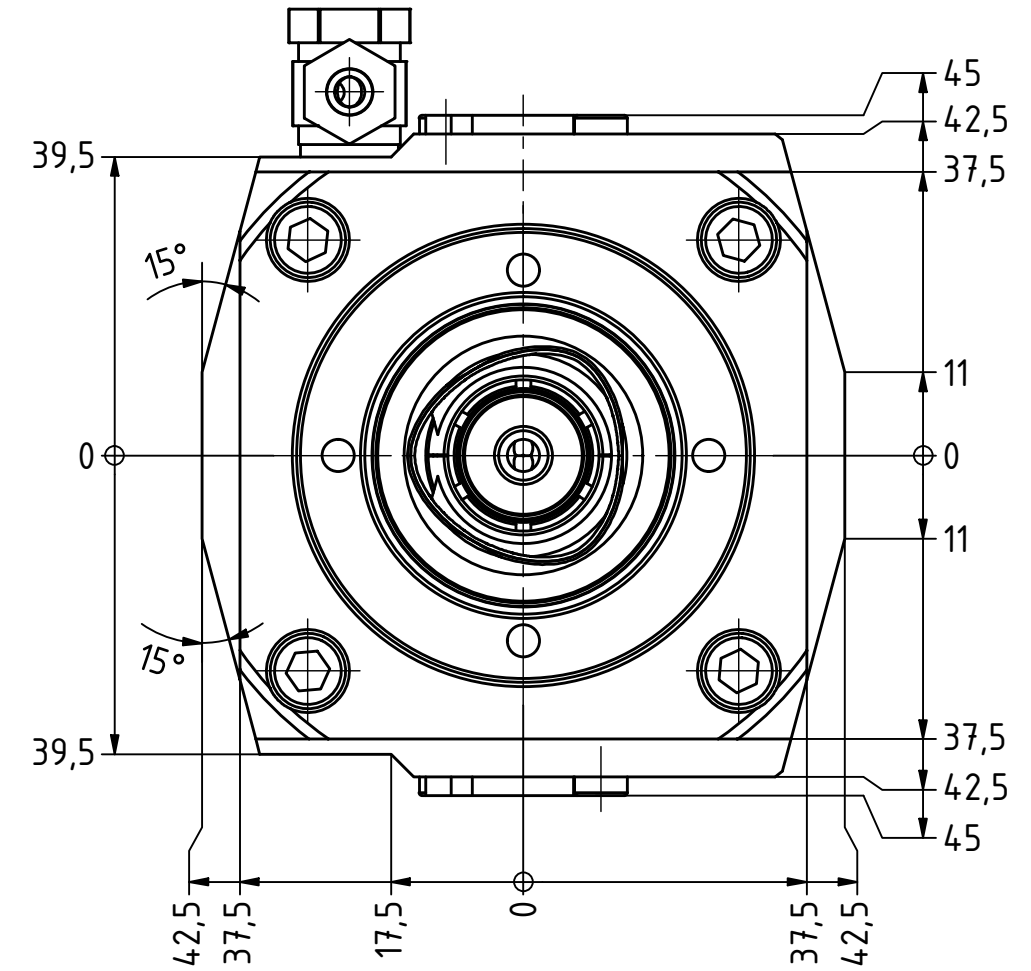
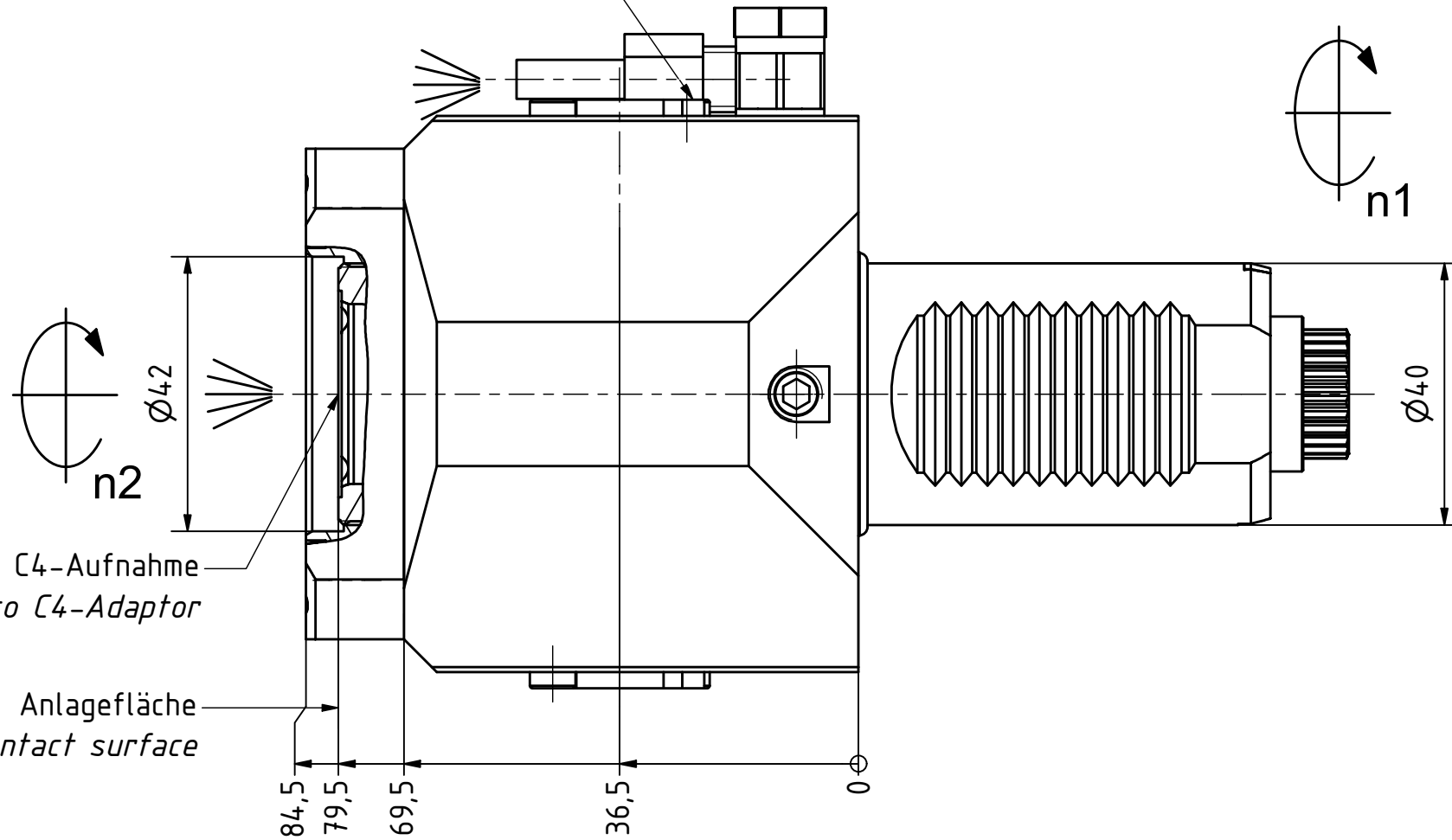

Capto C4-Aufnahme
Capto C4-Adaptor

Anlagefläche
contact surface

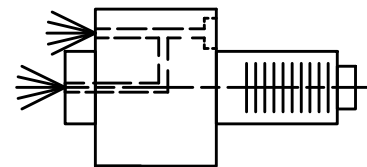

Innen- und Aussenkuehlung / Inside and outside coolant supply
Kuehlmittelfiltrierung<50µ / coolant filtration<50µ

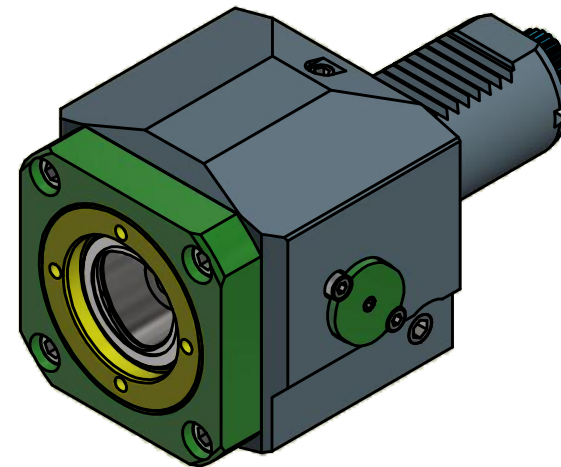

Copyright **EWS Tool Technologies**
Weitergabe und Vervielfaeltigung dieser Unterlage,
Verwertung und Mitteilung ihres Inhalts nicht
gestattet, soweit nicht ausdrucklich zugestanden.
Zuwaiderhandlungen verpflichten zu Schadenersatz.

Bemerkung - Note
Für Trockenlauf geeignet!
Use without coolant fluid allowed!

Technische Daten - technical data

Weight = 4.198 [kg]
 Torque max. (M1/M2) = 50 / 50 [Nm]
 Speed max. (n1/n2) = 6000 / 6000 [1/min]
 Gear ratio (i)=n1:n2 = 1:1
 Pressure (pmax) = 70 [bar]

Benennung - Title

Axial Bohr und Fräskopf
 Axial drilling and milling head



Nr. - No.
40.40C4CTXLIKC

Technische Aenderungen vorbehalten!
Subject to technical modifications!
IDENT: DEWS122135

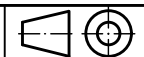

REV: -/C

MNR.
207384

QR