

Spannzange / collet ER32 DIN6499  
 Spannereich / clamping range: 2,0 - 20,0

Gewindebohrzange / tapping collet  
 ET-1-32 M5-M12

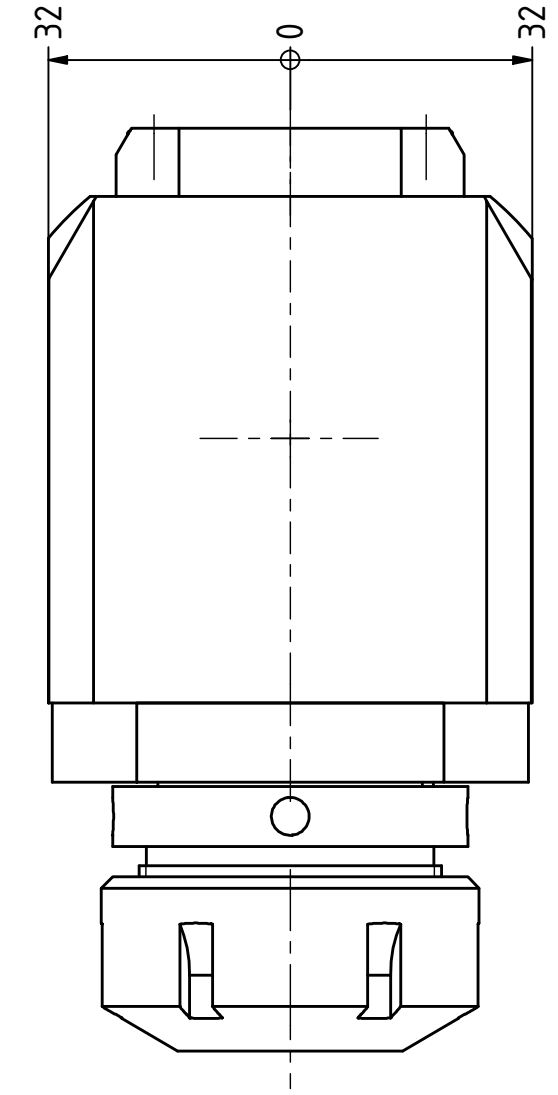

Spannzangenschlüssel  
 Clamping wrench  
 232



Hakenschlüssel  
 mit Zapfen  
 Hook wrench  
 with fixed pin  
 DIN1810 B 45x50

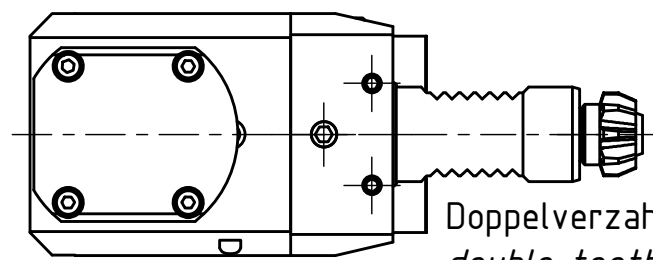
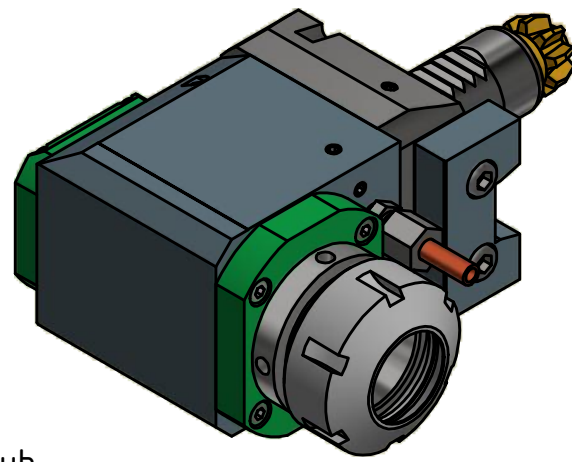

Doppelverzahnung Lizenz Traub  
 double tooth system licence Traub

Copyright **EWS Tool Technologies**  
 Weitergabe und Vervielfaeltigung dieser Unterlage,  
 Verwertung und Mitteilung ihres Inhalts nicht  
 gestattet, soweit nicht ausdrecklich zugestanden.  
 Zuwiderhandlungen verpflichten zu Schadenersatz.

Bemerkung - Note

Technische Daten - technical data

Weight	= 3.425 [kg]
Torque max. (M1/M2)	= 25 / 25 [Nm]
Speed max. (n1/n2)	= 8000 / 8000 [1/min]
Gear ratio (i)=n1:n2	= 1:1

Benennung - Title

Radial Bohr und Fräskopf  
 Radial drilling and milling head

**EWS** Tool Technologies  
 EWS Weigele GmbH & Co. KG  
 Maybachstr. 1  
 D-73066 Uhingen  
 www.ews-tools.de

Nr. - No.  
 60.2532ABCRLV

Technische Aenderungen vorbehalten!  
 Subject to technical modifications!

IDENT: DEWS081758

REV: -/A

MNR.  
 215514

