

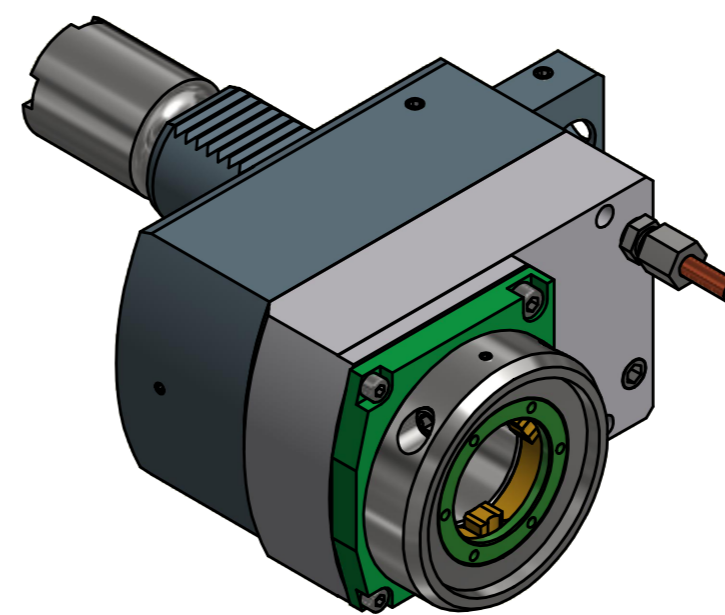

Innen- und Aussenkuehlung / Inside and outside coolant supply  
 Kein Trockenlauf / No dry run  
 Kuehlmittelfiltrierung=50µ / coolant filtration=50µ



Copyright **EWS Tool Technologies**  
 Weitergabe und Vervielfaeltigung dieser Unterlage,  
 Verwertung und Mitteilung ihres Inhalts nicht  
 gestattet, soweit nicht ausdrecklich zugestanden.  
 Zuwiderhandlungen verpflichten zu Schadenersatz.

<p>Bemerkung - Note                  Nicht ohne Kuehlmittel betreiben!                  Not for use without coolant-fluid!</p>	<p>Technische Daten - technical data                  Weight = 6.924 [kg]                  Torque max. (M1/M2) = 50 / 25 [Nm]                  Speed max. (n1/n2) = 6000 / 12000 [1/min]                  Gear ratio (i)=n1:n2 = 1:2                  Pressure (pmax) = 70 [bar]</p>	<p>Benennung - Title  <b>Axial Bohr u. Fräskopf achsversetzt</b>  <b>Ax. drill. and mill. head offset</b></p>	<p><b>EWS</b> Tool Technologies                  EWS Weigle GmbH &amp; Co. KG                  Maybachstr. 1                  D-73066 Uhlingen                  www.ews-tools.de</p>	<p>Technische Aenderungen vorbehalten!                  Subject to technical modifications!                  IDENT: DEWS131042                  REV: -/A</p>	<p>Nr. - No.  <b>50.40VX4LB25LIK1</b>                  MNR.  <b>223189</b></p>	
--	--	---	--	--	--	---