

Innen- und Aussenkuehlung / Inside and outside coolant supply  
Kuehlmittelfiltrierung<50µ / coolant filtration<50µ

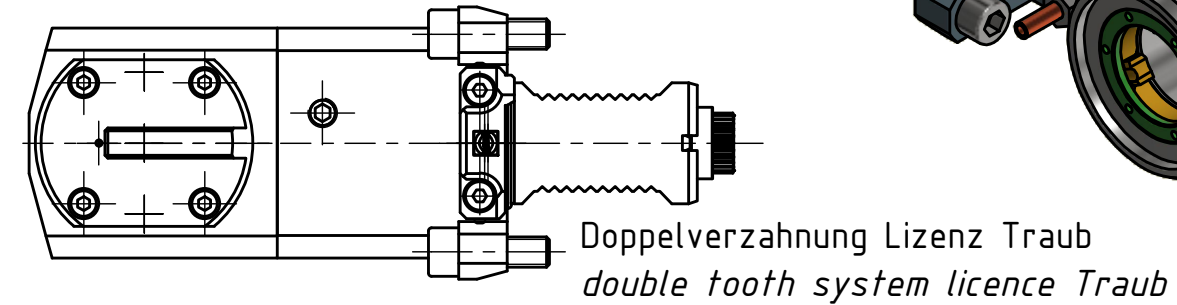

Copyright **EWS Tool Technologies**  
Weitergabe und Vervielfaeltigung dieser Unterlage,  
Verwertung und Mitteilung ihres Inhalts nicht  
gestattet, soweit nicht ausdrecklich zugestanden.  
Zuwiderhandlungen verpflichten zu Schadenersatz.

Bemerkung - Note  
Für Trockenlauf geeignet!  
Use without coolant fluid allowed!

Technische Daten - technical data

Weight	= 8.384 [kg]
Torque max. (M1/M2)	= 50 / 50 [Nm]
Speed max. (n1/n2)	= 10000 / 10000 [1/min]
Gear ratio (i)=n1:n2	= 1:1
Pressure (pmax)	= 70 [bar]

Benennung - Title  
**Radial Bohr und Fräskopf**  
**Radial drilling and milling head**

 <small>EWS Weigele GmbH &amp; Co. KG Maybachstr. 1 D-73066 Utingen www.ews-tools.de</small>	Technische Aenderungen vorbehalten! Subject to technical modifications! IDENT: DEWS132335	 REV: -/A	
	Nr. - No. <b>60.40VX4LCTXRLIKDTFL-PLHSD10</b>	MNR. <b>223508</b>	