

Spannzange / collet ER25 DIN64.99  
Spannbereich / clamping range: 1,0 - 16,0

Gewindebohrzange / tapping collet  
ET-1-25 M3-M12

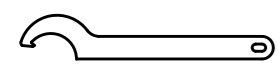

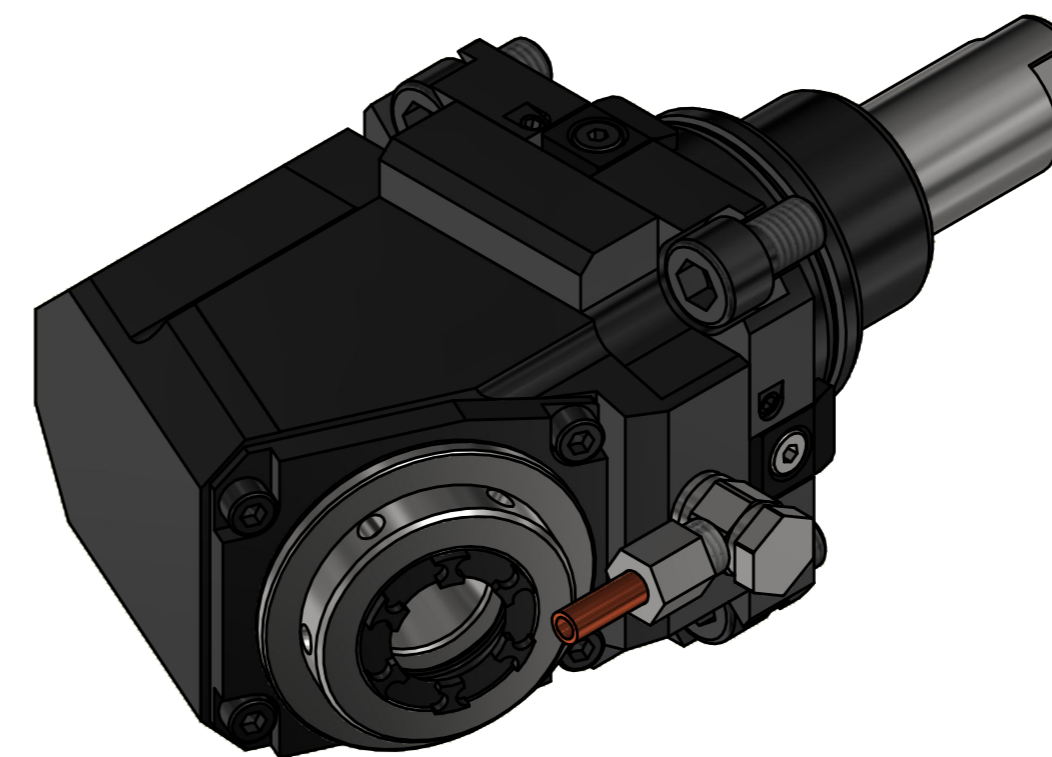
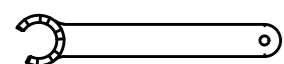

Hakenschlüssel  
mit Nase  
Hook wrench with  
nose end  
DIN1810 A 45x50



Spannzangenschlüssel für  
innenliegende Mutter  
Clamping wrench for  
internal collet  
225AX

Copyright **EWS Tool Technologies**  
Weitergabe und Vervielfältigung dieser Unterlage,  
Verwertung und Mitteilung ihres Inhalts nicht  
gestattet, soweit nicht ausdrücklich zugestanden.  
Zuwerhandlungen verpflichten zu Schadenersatz.

Bemerkung - Note 	Technische Daten - technical data Weight = 3.846 [kg] Torque max. (M1/M2) = 25 / 25 [Nm] Speed max. (n1/n2) = 6000 / 6000 [1/min] Gear ratio (i)=n1:n2 = 1:1	Benennung - Title <b>Radial Bohr und Fräskopf</b> <b>Radial drilling and milling head</b>	 <b>EWS</b> Weigle GmbH & Co. KG Maybachstr. 1 D-73066 Uhingen www.ews-tools.de	Technische Änderungen vorbehalten! Subject to technical modifications! IDENT: DEWS046578 REV: -/C MNR. 207506	
----------------------	--	---	---	--	---