

Spannzange / collet ER25 DIN6499
 Spannbereich / clamping range: 1,0 - 16,0

Gewindebohrzange / tapping collet
 ET-1-25 M3-M10

Trifix Anzugsdrehmoment 10 Nm
 Trifix clamping torque 10 Nm

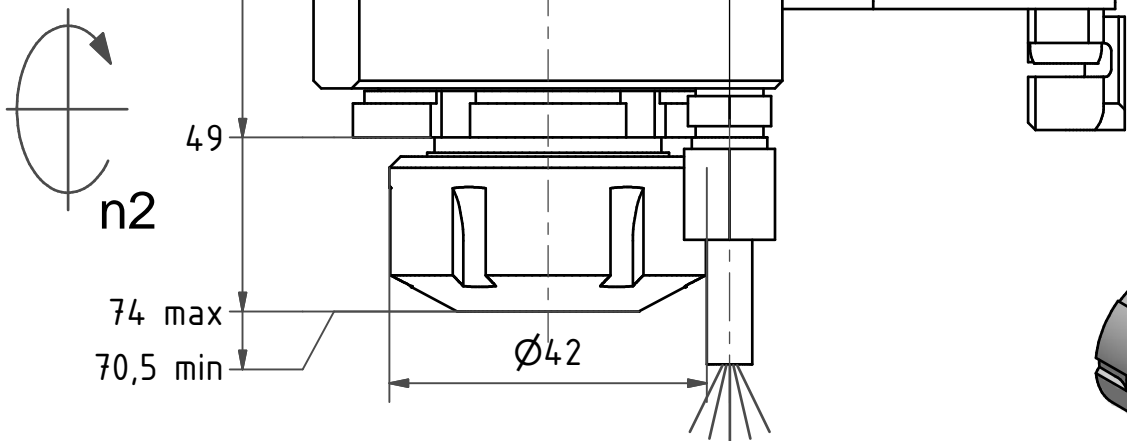
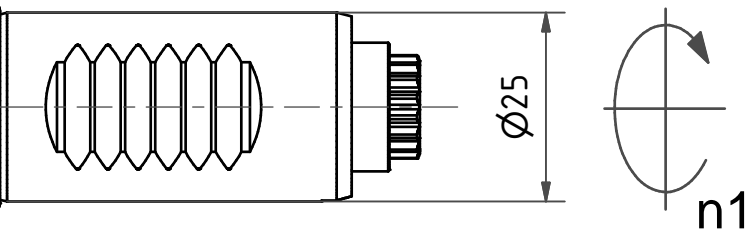

Spannzange / collet ER25 DIN6499
 Spannbereich / clamping range: 1,0 - 16,0

Gewindebohrzange / tapping collet
 ET-1-25 M3-M10

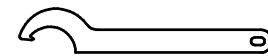
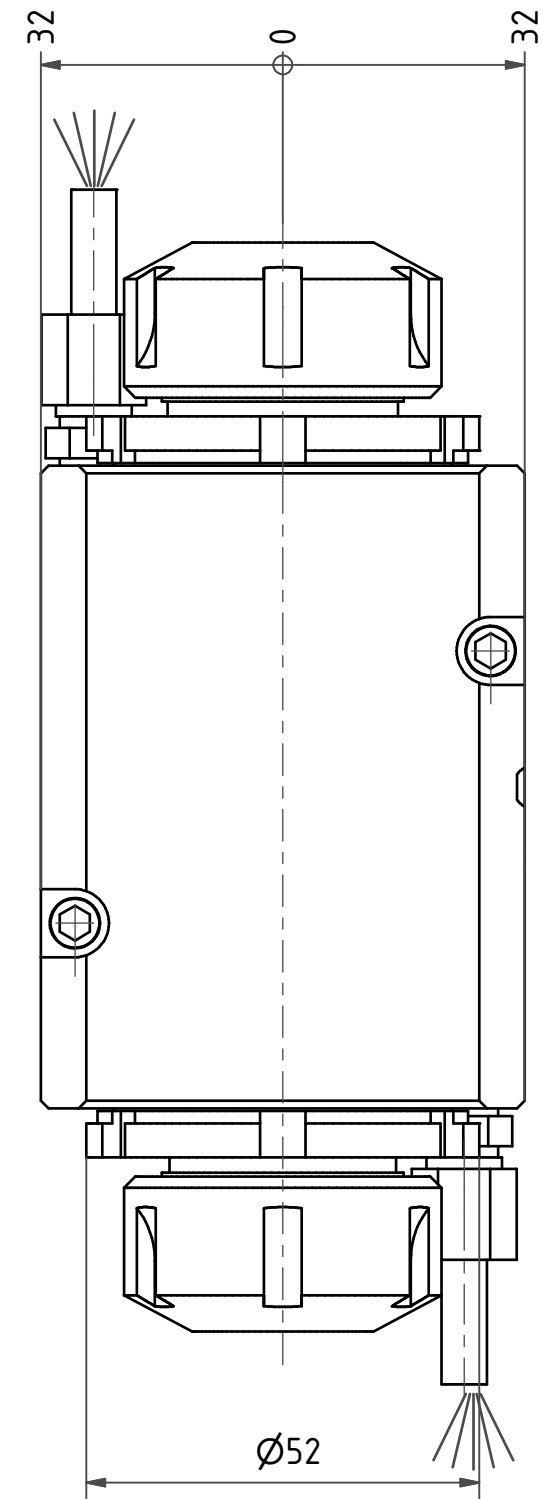
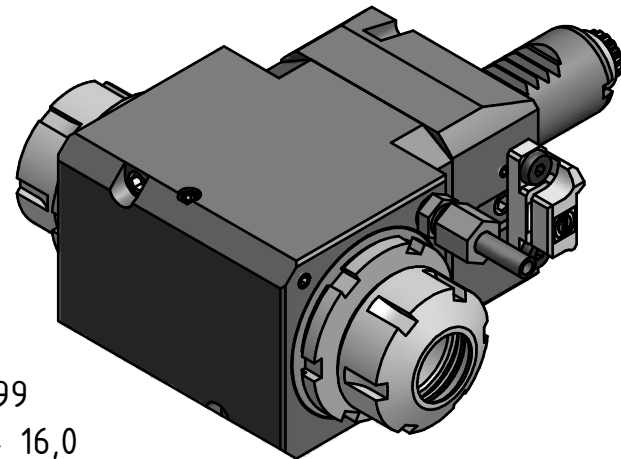

Hakenschlüssel
 mit Nase
 Hook wrench with
 nose end
 DIN1810 A 52x55



Spannzangenschlüssel
 Clamping wrench
 225

Copyright **EWS Tool Technologies**
 Weitergabe und Vervielfältigung dieser Unterlage,
 Verwertung und Mitteilung ihres Inhalts nicht
 gestattet, soweit nicht ausdrücklich zugestanden.
 Zuwiderhandlungen verpflichten zu Schadenersatz.

Bemerkung - Note

Technische Daten - technical data

Weight = 3.956 [kg]
 Torque max. (M1/M2) = 25 / 25 each Sp. [Nm]
 Speed max. (n1/n2) = 12000 / 12000 [1/min]
 Gear ratio (i)=n1:n2 = 1:1

Benennung - Title

Radial Bohr und Fräskopf
 Radial drilling and milling head



Nr. - No.
 60.2525LD5480TFHSD12

Technische Änderungen vorbehalten!
 Subject to technical modifications!

IDENT: D-EWS-191510

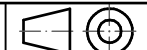

REV: A/-

MNR.

188520

