

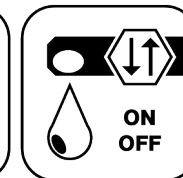

Butterfly Seal



Coolant Management



Tech Details

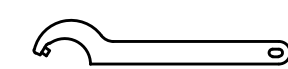
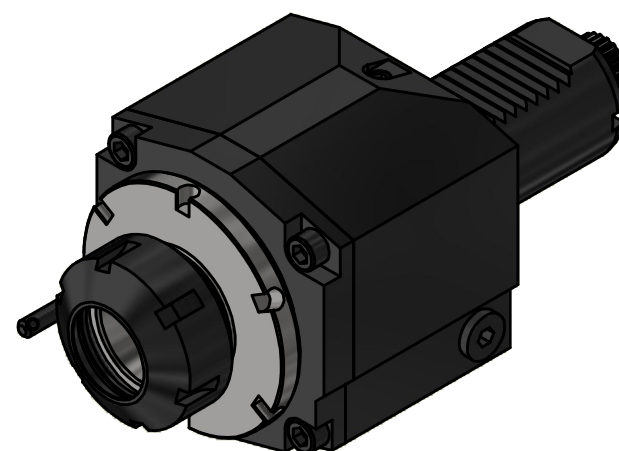
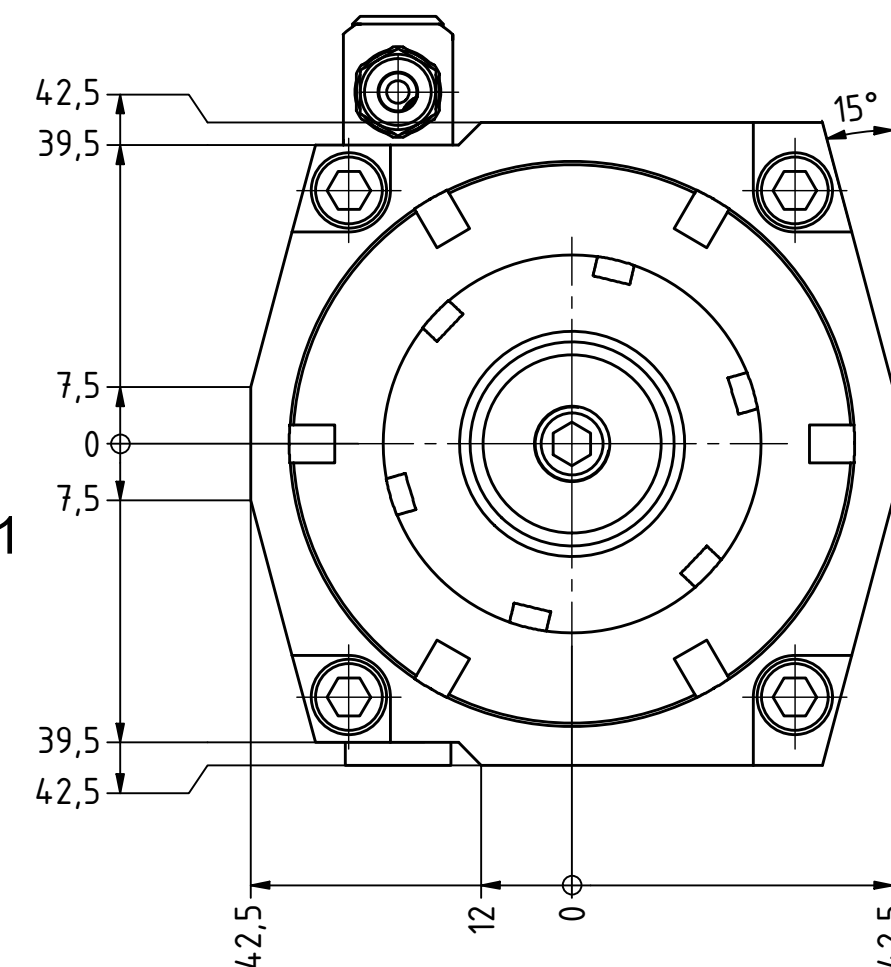
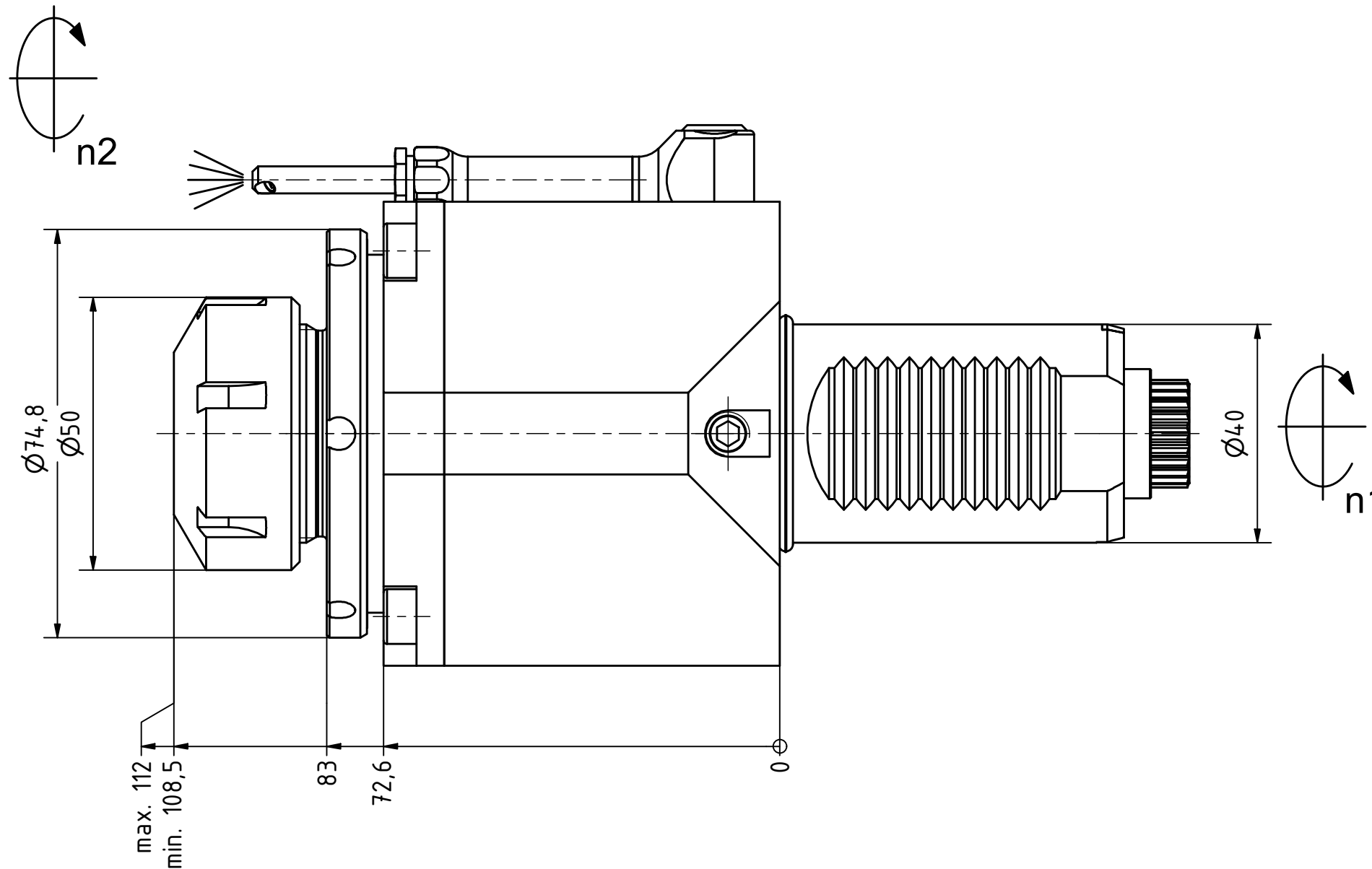

Hakenschlüssel mit Zapfen
Hook wrench with fixed pin
DIN1810 B 68x75

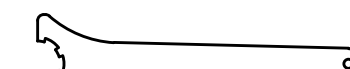

Spannzangenschlüssel
Clamping wrench
232

Spannzange / collet ER32 DIN6499
Spannbereich / clamping range: 2,0 - 20,0

Gewindebohrzange / tapping collet
ET-1-32 M5-M12

Copyright **EWS Tool Technologies**
Weitergabe und Vervielfaeltigung dieser Unterlage, Verwertung und Mitteilung ihres Inhalts nicht gestattet, soweit nicht ausdrecklich zugestanden. Zuwiderhandlungen verpflichten zu Schadenersatz.

Bemerkung - Note
mit Kegeltrollenlager
with taper roller bearing(s)

Technische Daten - technical data
Weight = 4.451 [kg]
Torque max. (M1/M2) = 63 / 63 [Nm]
Speed max. (n1/n2) = 5000 / 5000 [1/min]
Gear ratio (i)=n1:n2 = 1:1

Benennung - Title
Axial Bohr und Fräskopf
Axial drilling and milling head

EWS Tool Technologies
EWS Weigele GmbH & Co. KG
Maybachstr. 1
D-73066 UHINGEN
www.ews-tools.de
Nr. - No.
40.4032KRCTX#01

Technische Aenderungen vorbehalten!
Subject to technical modifications!
IDENT: DEWS154798
REV: -/B
MNR.
222755

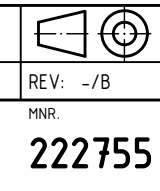

QR