

EWS.Varia

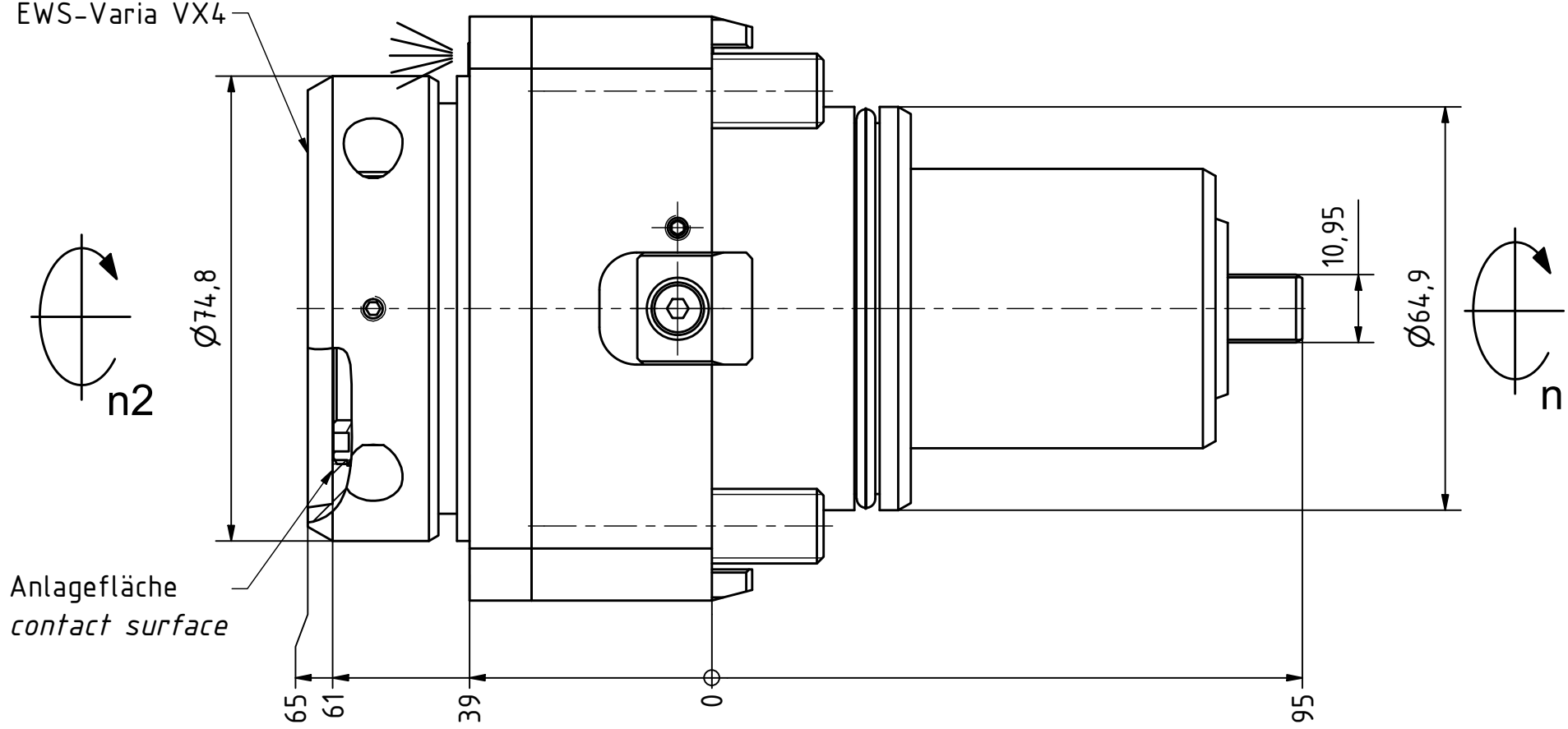

Tech  
Details

EWS-Varia VX4



Anlagefläche  
contact surface

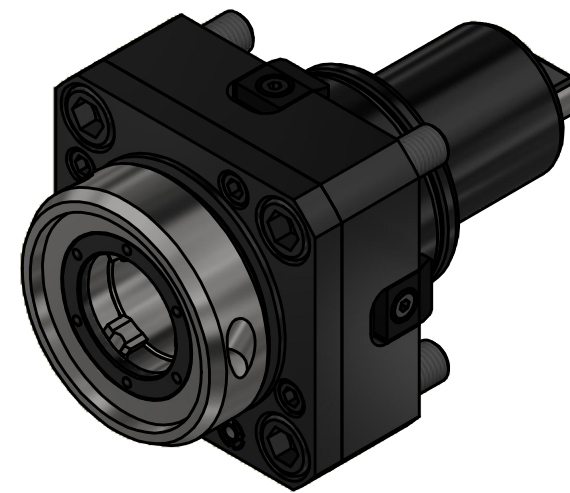
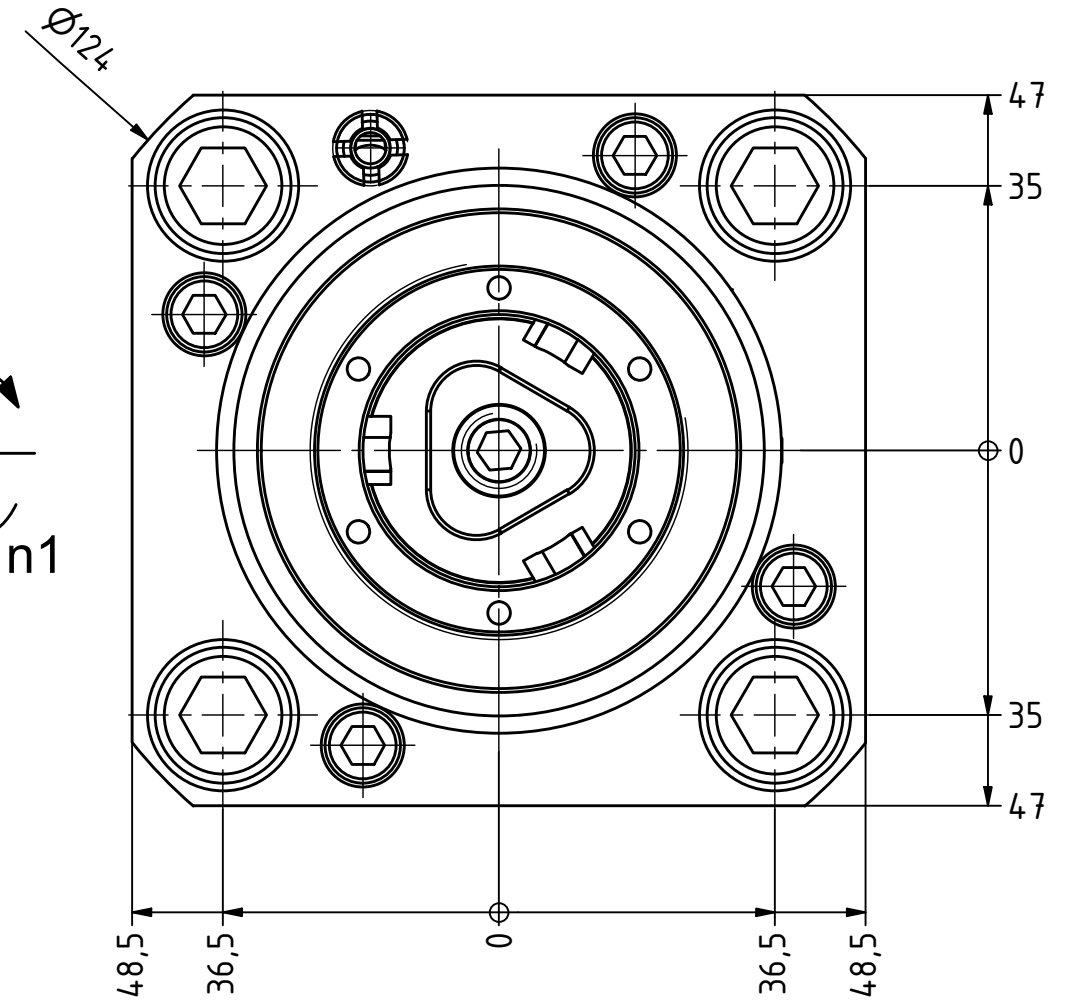

Copyright **EWS Tool Technologies**  
Weitergabe und Vervielfaeltigung dieser Unterlage,  
Verwertung und Mitteilung ihres Inhalts nicht  
gestattet, soweit nicht ausdrecklich zugestanden.  
Zuwiderhandlungen verpflichten zu Schadenersatz.

Bemerkung - Note

Technische Daten - technical data

Weight = 4.169 [kg]  
Torque max. (M1/M2) = 70 / 70 [Nm]  
Speed max. (n1/n2) = 6000 / 6000 [1/min]  
Gear ratio (i)=n1:n2 = 1:1

Benennung - Title

**Axial Bohr und Fräskopf**  
**Axial drilling and milling head**



EWS Weigle GmbH & Co. KG  
Maybachstr. 1  
D-73066 Uhingen  
www.ews-tools.de

Technische Aenderungen vorbehalten!  
Subject to technical modifications!

IDENT: DEWS127348



REV: -/B

Nr. - No.

**40.65VX4VLHP6**

MNR.

**222613**

**QR**