



Ceramic Seal



Highspeed



Tech Details

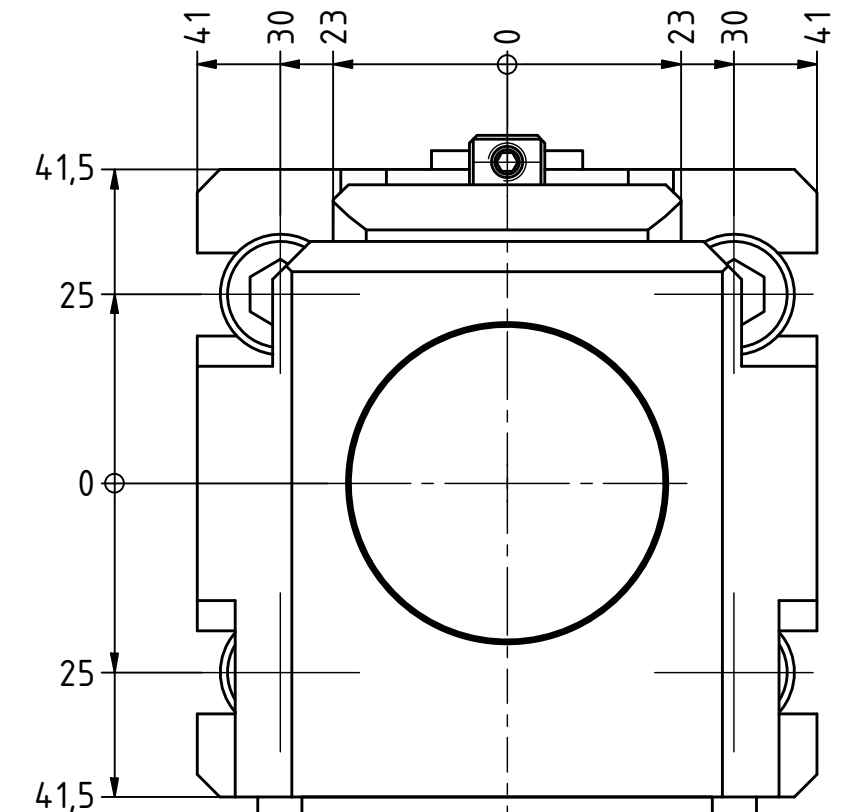
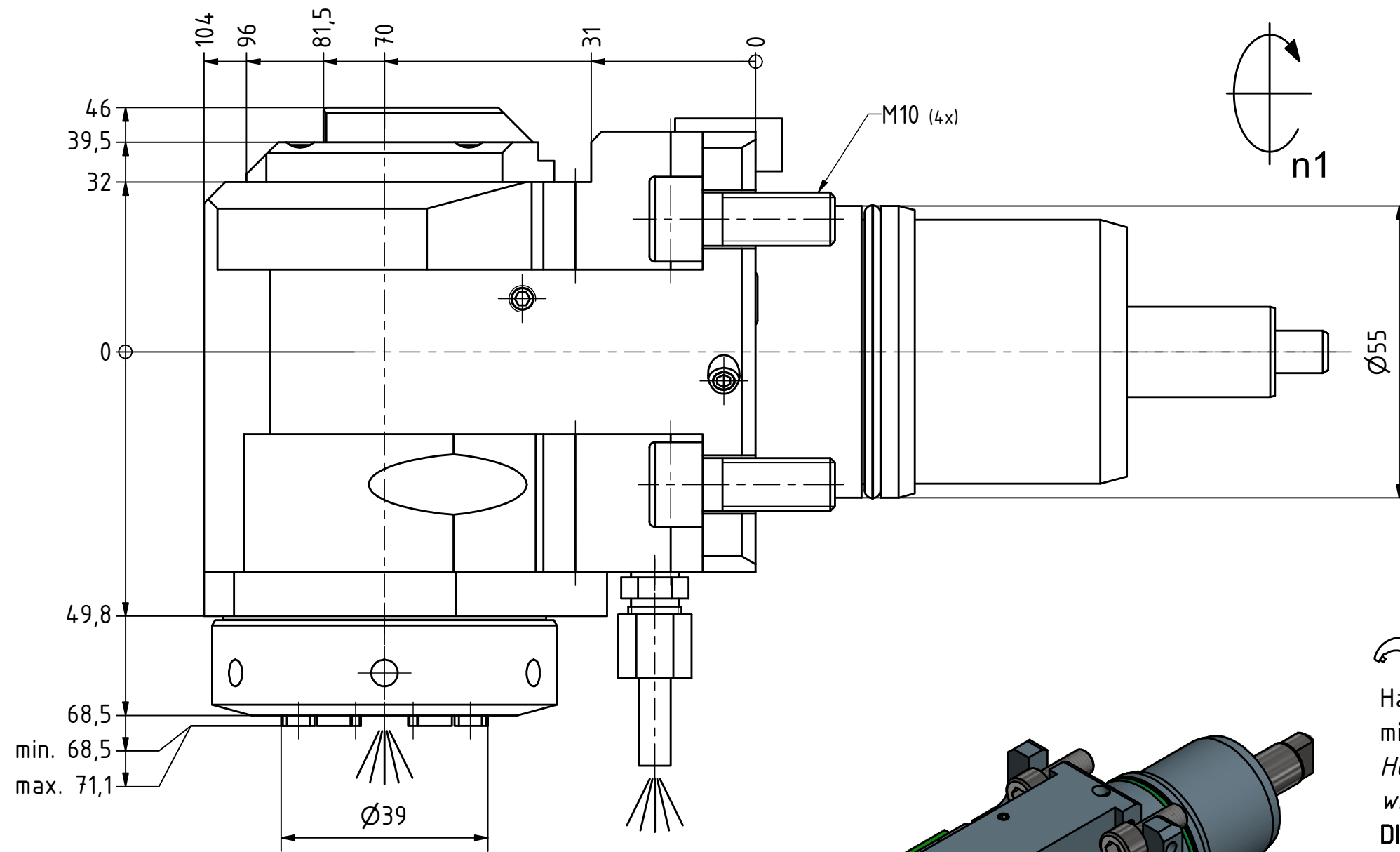

Hakenschlüssel mit Zapfen
Hook wrench with fixed pin
DIN1810 B 68x75

Spannzangenschlüssel für innenliegende Mutter
Clamping wrench for internal collet
232AX

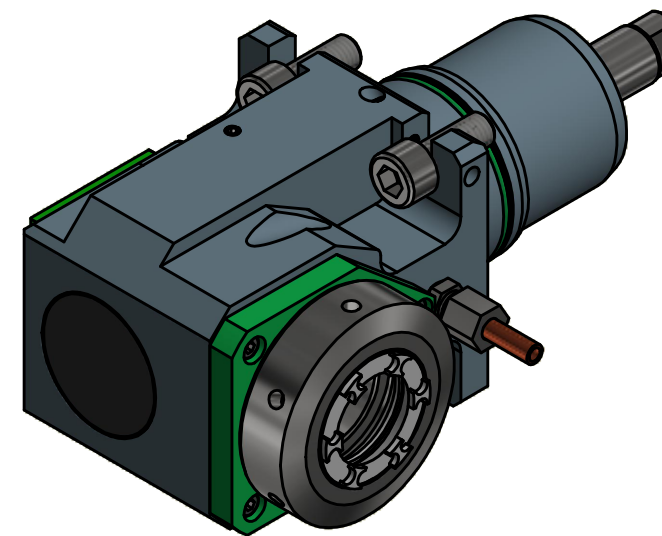

Spannzange / collet ER32 DIN6499
Spannbereich / clamping range: 2,0 - 20,0

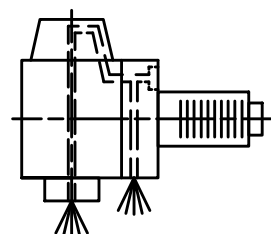

Innen- und Aussenkuehlung / Inside and outside coolant supply
Kuehlmittelfiltrierung=50µ / coolant filtration=50µ

Copyright **EWS Tool Technologies**
Weitergabe und Vervielfaeltigung dieser Unterlage,
Verwertung und Mitteilung ihres Inhalts nicht
gestattet, soweit nicht ausdrecklich zugestanden.
Zuwiderhandlungen verpflichten zu Schadenersatz.

Bemerkung - Note
Für Trockenlauf geeignet!
Use without coolant fluid allowed!

Technische Daten - technical data	
Weight	= 4.885 [kg]
Torque max. (M1/M2)	= 25 / 25 [Nm]
Speed max. (n1/n2)	= 12000 / 12000 [1/min]
Gear ratio (i)=n1:n2	= 1:1
Pressure (pmax)	= 70 [bar]

Benennung - Title
Radial Bohr und Fräskopf
Radial drilling and milling head



Nr. - No.
60.5532TW10IKDIMHSD12

Technische Aenderungen vorbehalten!
Subject to technical modifications!
IDENT: DEWS127780

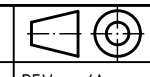

REV: -/A

MNR.
222647

