

Spannzange / collet ER32 DIN6499  
 Spannbereich / clamping range: 2,0 - 20,0

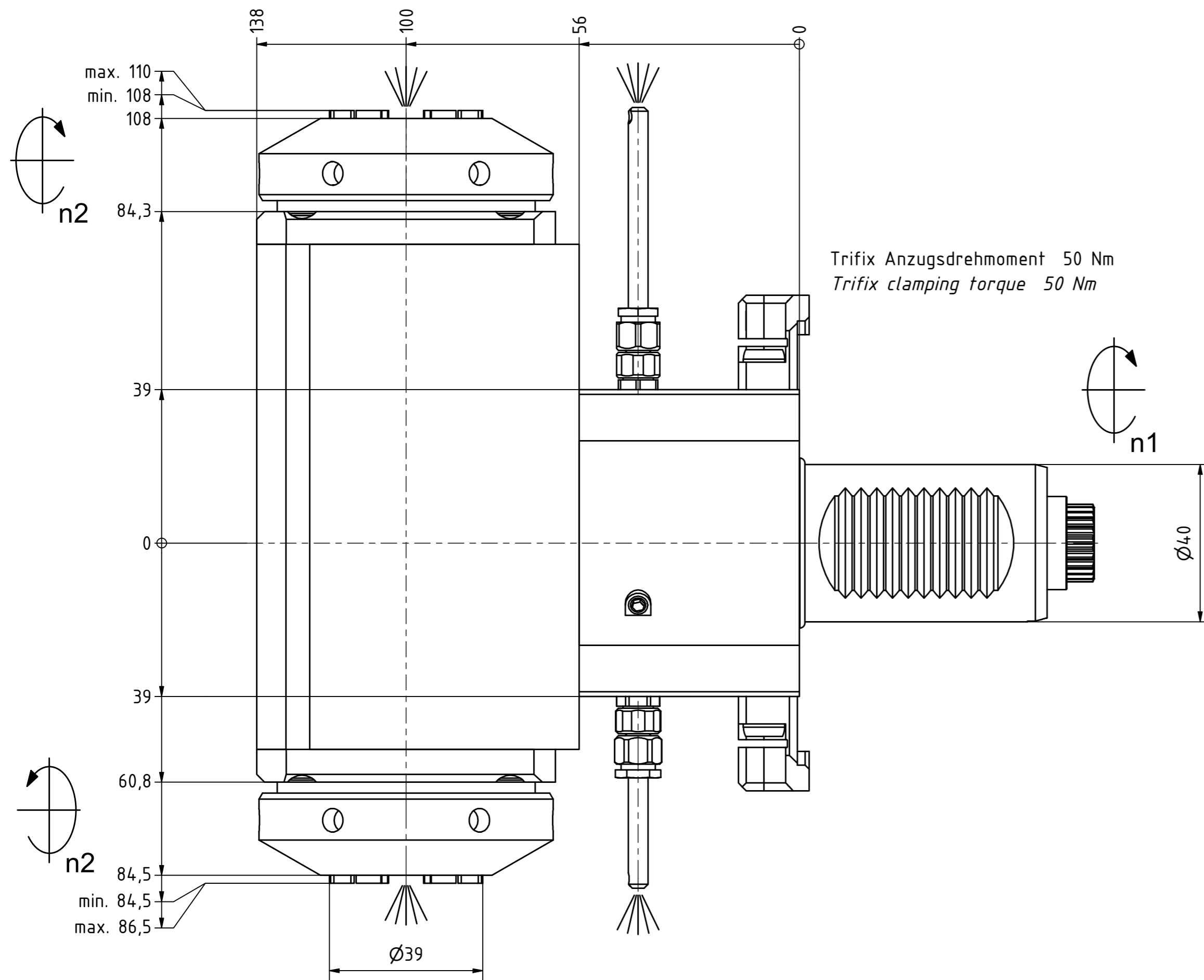

Trifix Anzugsdrehmoment 50 Nm  
 Trifix clamping torque 50 Nm

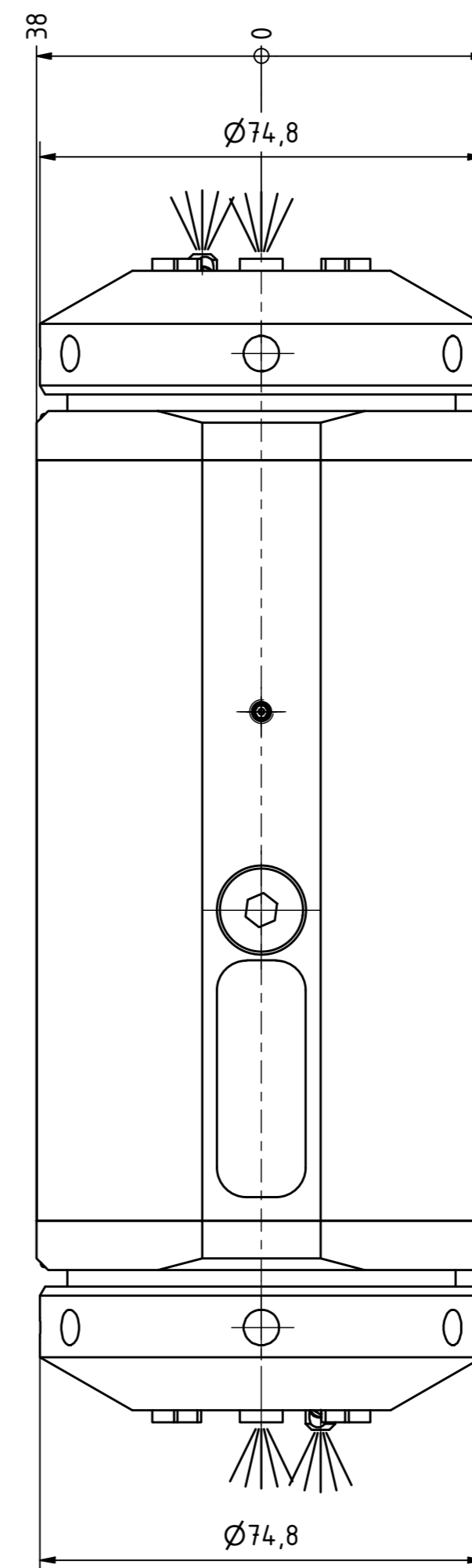
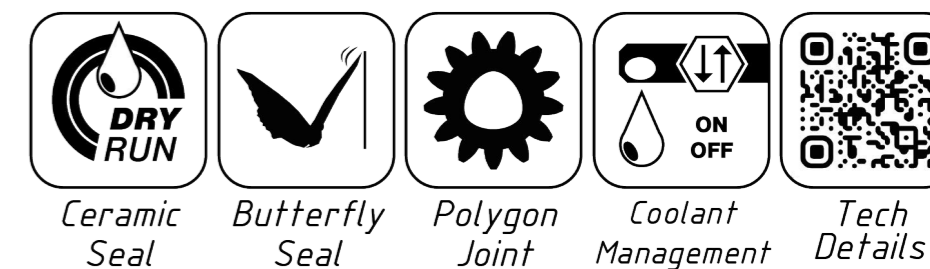

Spannzange / collet ER32 DIN6499  
 Spannbereich / clamping range: 2,0 - 20,0

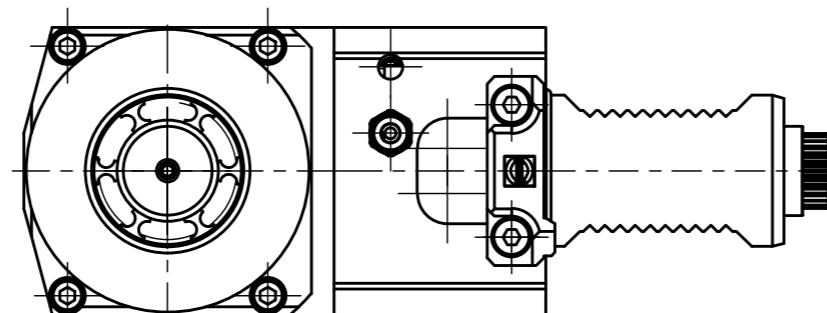

Doppelverzahnung Lizenz Traub  
 double tooth system licence Traub

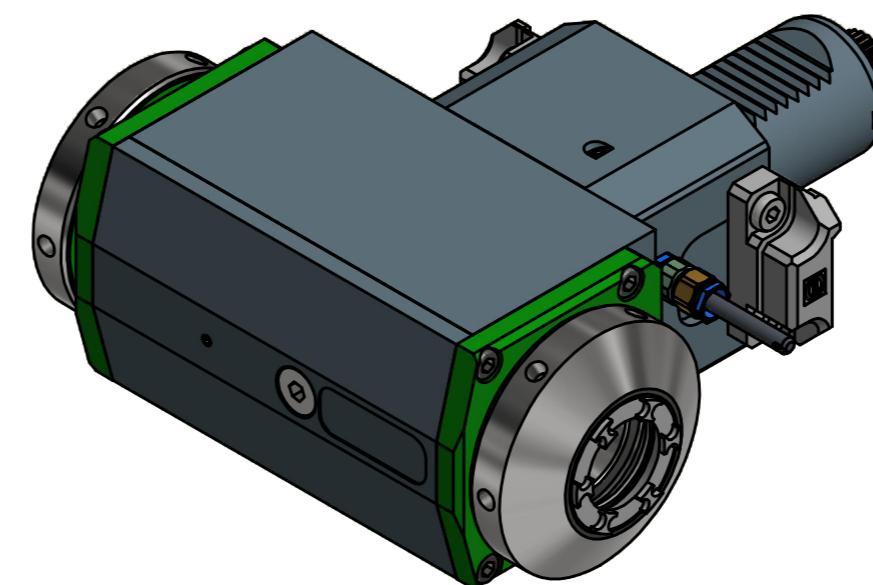

Radial Bohr und Fräskopf  
 Radial drilling and milling head

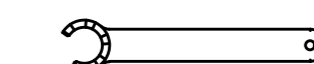

Spannzangenschlüssel für  
 innenliegende Mutter  
 Clamping wrench for  
 internal collet  
 232AX



Hakenschlüssel  
 mit Zapfen  
 Hook wrench  
 with fixed pin  
 DIN1810 B 68x75

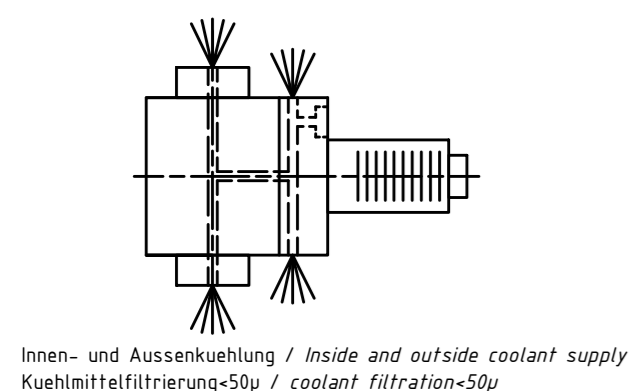

Innen- und Aussenkuehlung / Inside and outside coolant supply  
 Kuehmittelfiltrierung<50µ / coolant filtration<50µ

Bemerkung - Note	Technische Daten - technical data
Für Trockenlauf geeignet! Use without coolant fluid allowed!	Weight = 9.531 [kg] Torque max. (M1/M2) = 63 / 63   63 [Nm] Speed max. (n1/n2) = 6000 / 6000   6000 [1/min] Gear ratio (i)=n1:n2 = 1:1   1:1 Pressure (pmax) = 70 [bar]

Benennung - Title
Radial Bohr und Fräskopf Radial drilling and milling head

EWS Weigle GmbH & Co. KG Maybachstr. 1 D-73066 Uhlingen www.ews-tools.de	Technische Aenderungen vorbehalten! Subject to technical modifications! IDENT: DEWS137000	REV: -/B MNR.
	Nr. - No. 60.4032DCTXRLIKDTRIM#01	222504

Copyright EWS Tool Technologies  
 Weitergabe und Vervielfaeltigung dieser Unterlage,  
 Verwertung und Mitteilung ihres Inhalts nicht  
 gestattet, soweit nicht ausdrecklich zugestanden.  
 Zuwiderhandlungen verpflichten zu Schadenersatz.