

max. Fraeserdurchmesser $\varnothing 100$
 max. saw milling diameter

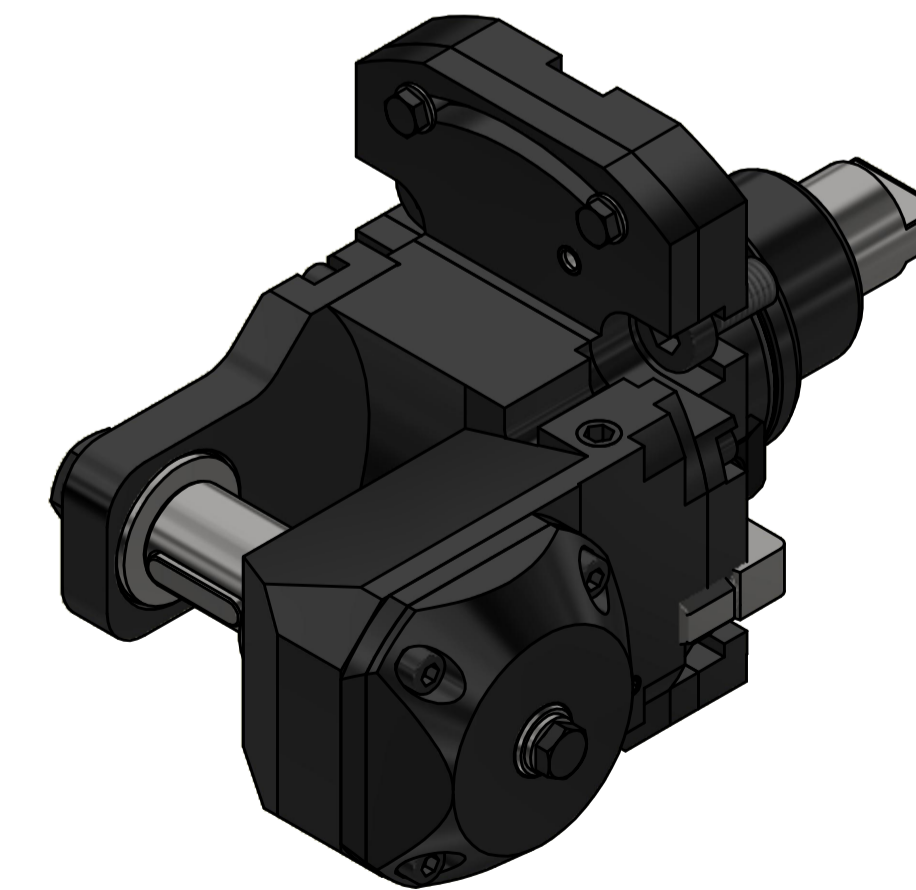
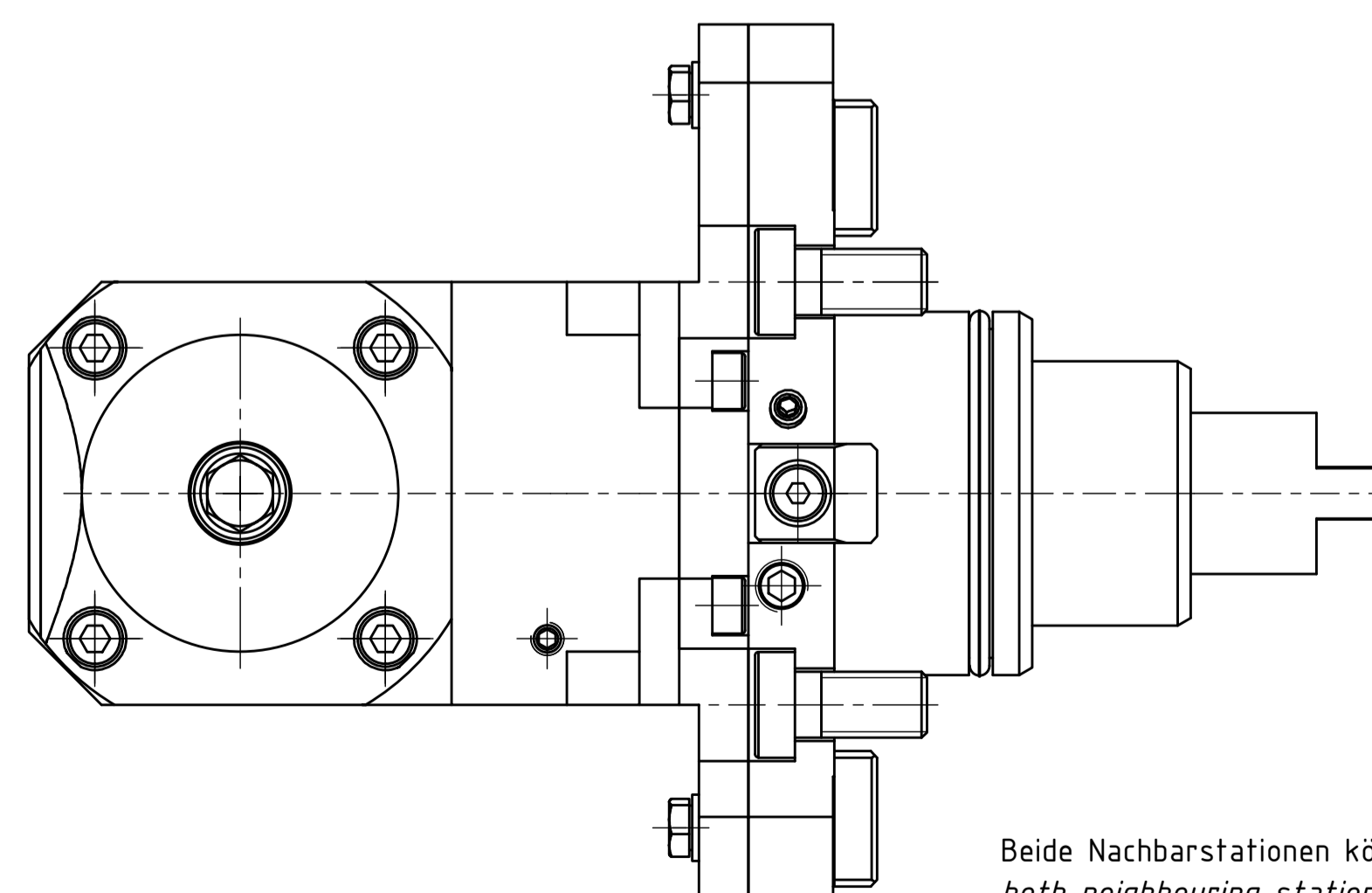
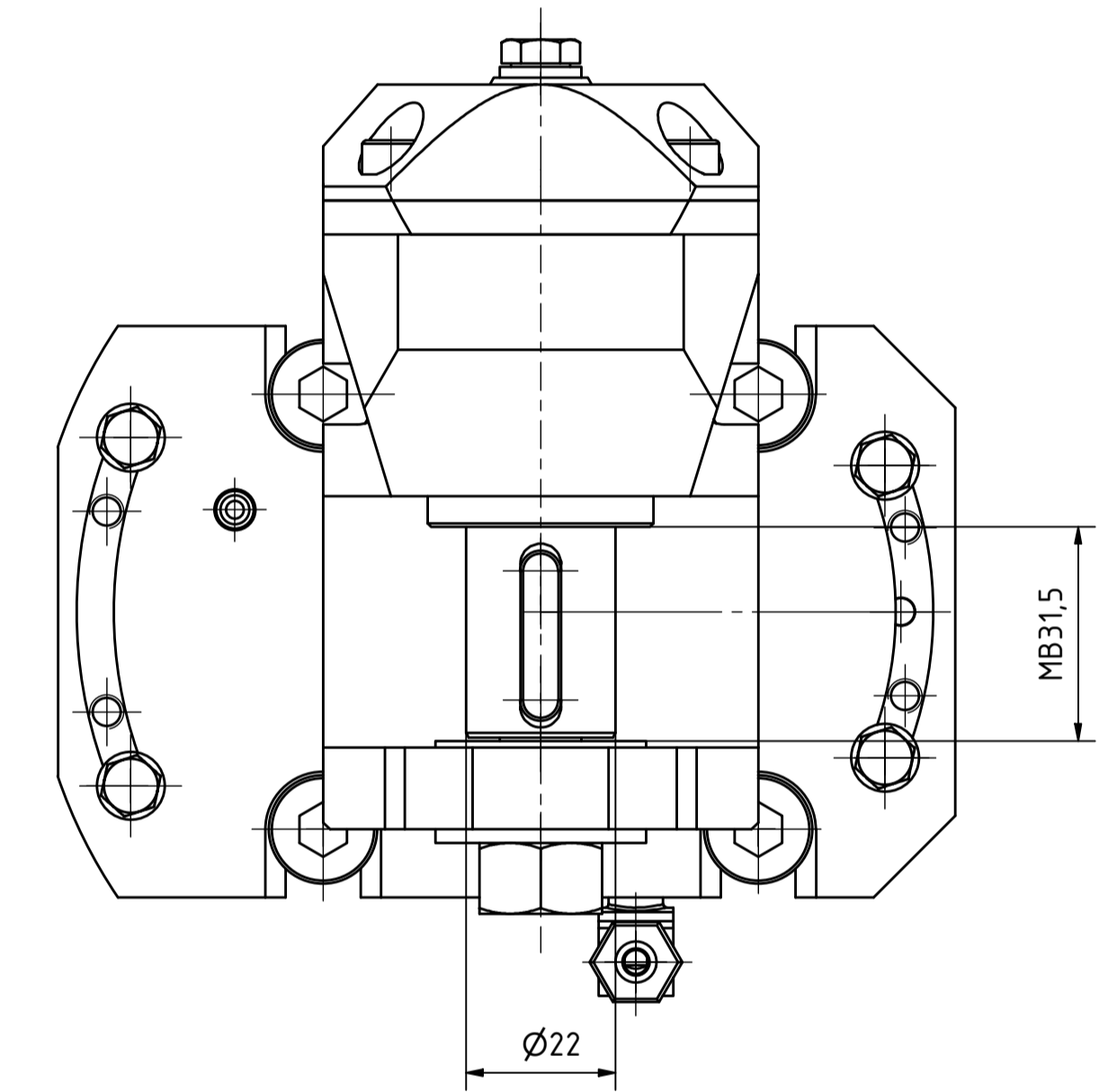
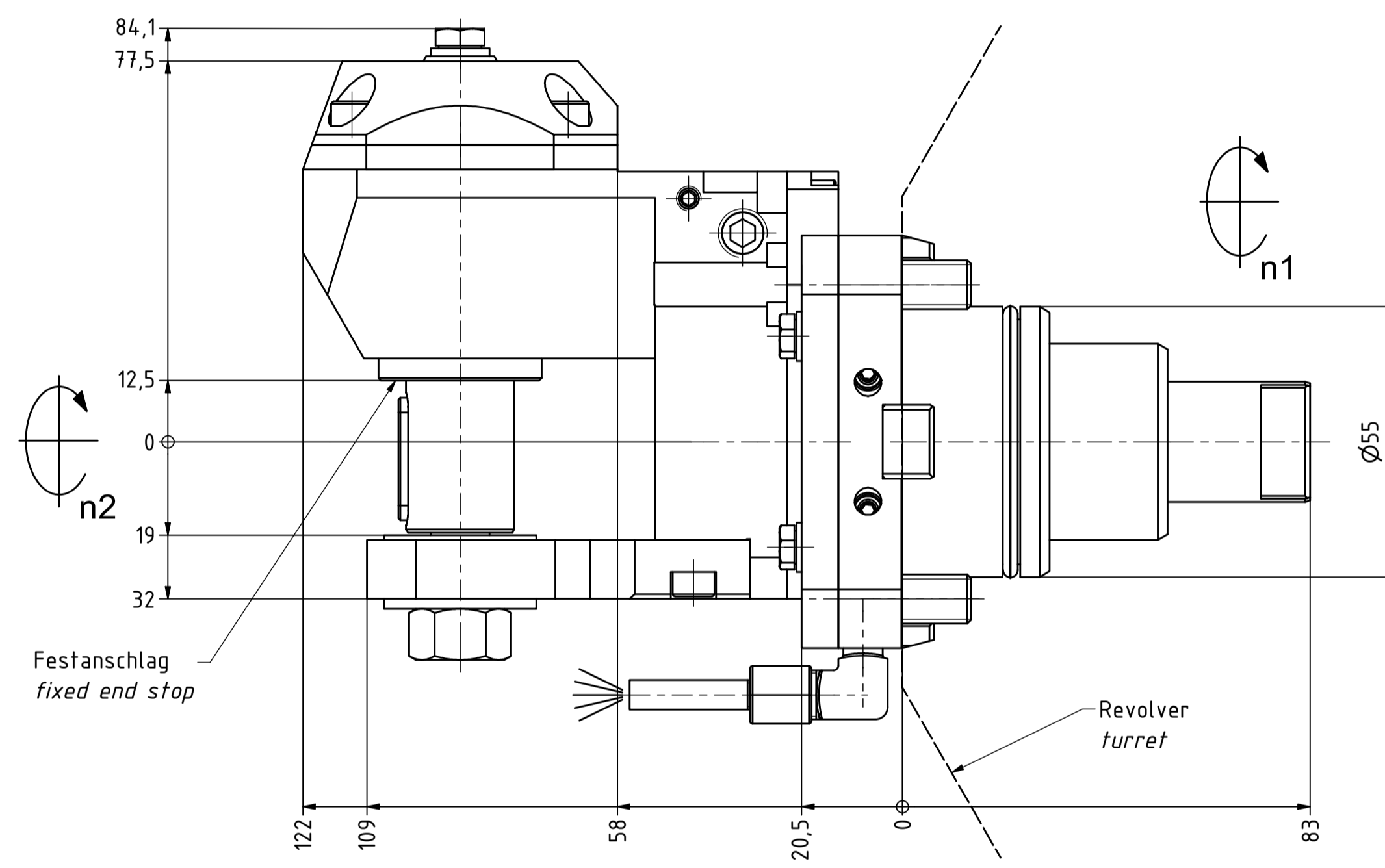
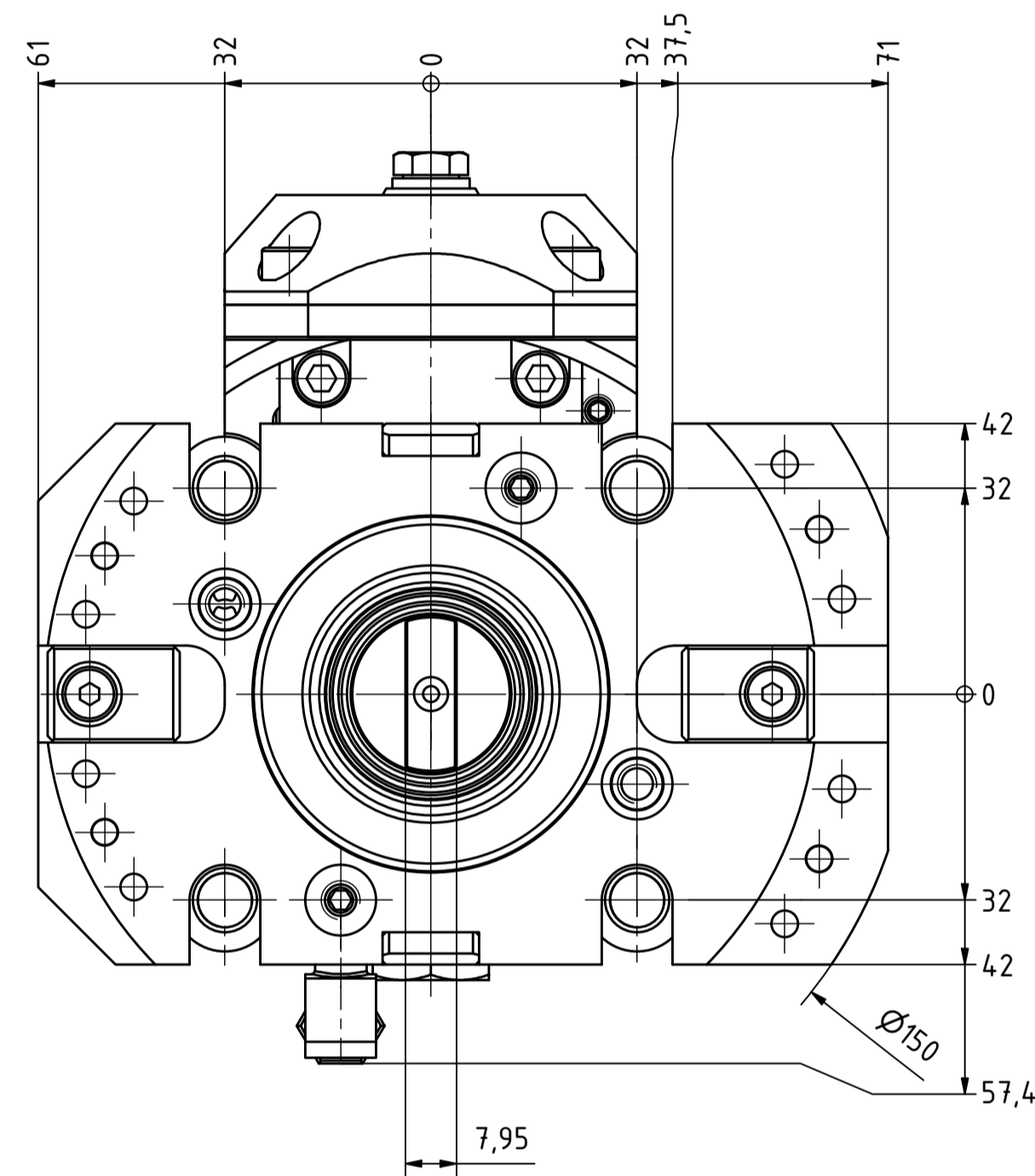
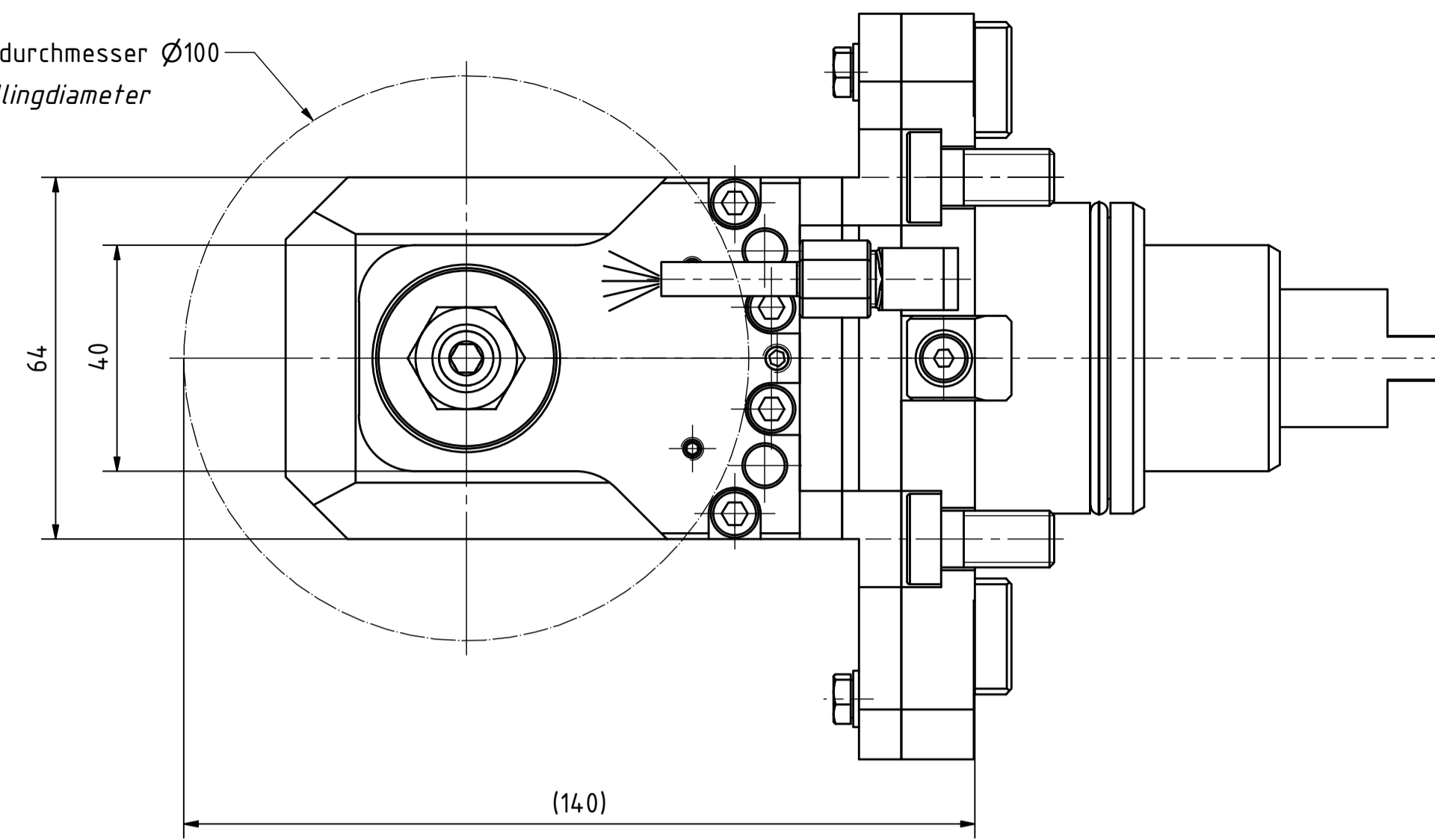

Beide Nachbarstationen könnten entfallen!
 both neighbouring stations may be lost!

Bemerkung - Note 	Technische Daten - technical data Weight = 5.216 [kg] Torque max. (M1/M2) = 20 / 60 [Nm] Speed max. (n1/n2) = 6000 / 2000 [1/min] Gear ratio (i)=n1:n2 = 3:1	Bezeichnung - Title Scheibenfräserkopf Radial saw milling head	EWS Werkzeug GmbH & Co. KG Hauptstr. 1 64700 Kelkheim www.ews-tool.de Technische Änderungen vorbehalten! Subject to technical modifications! IDENT: DEWS078511 Nr. - No. 64.5522VL213\varnothing 100-S01	HNB REV. - /JD 215051 
--------------------------	--	---	--	--

Copyright EWS Tool Technologies
 Weitergabe und Vervielfältigung dieser Unterlage,
 Verwertung und Mitteilung ihres Inhalts nicht
 gestattet, soweit nicht ausdrücklich zugestanden.
 Zuwiderhandlungen verpflichten zu Schadenersatz.