

Spannzange / collet ER25 DIN6499  
Spannbereich / clamping range: 1,0 - 16,0

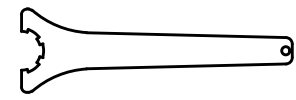

Spannzangenschlüssel  
Clamping wrench  
225

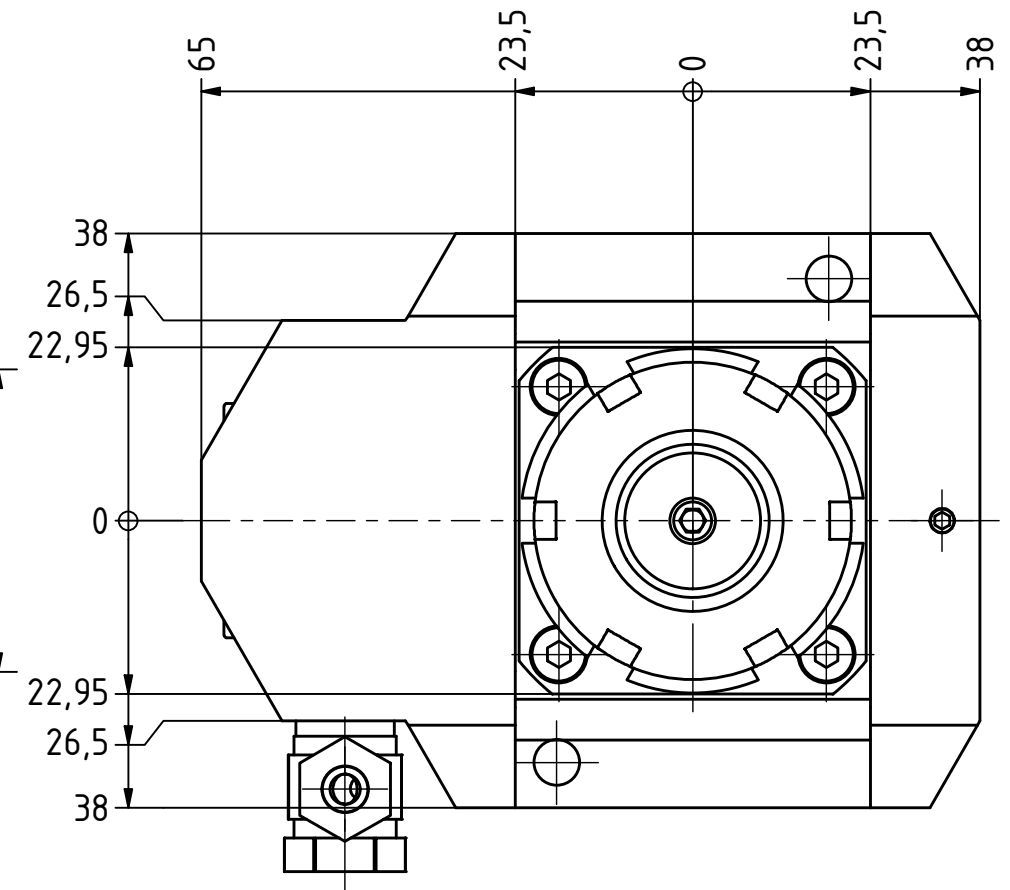
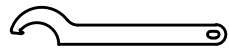

Hakenschlüssel  
mit Nase  
Hook wrench with  
nose end  
DIN1810 A 45x50

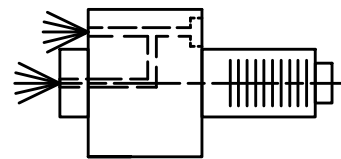

Doppelverzahnung Lizenz Traub  
double tooth system licence Traub

Innen- und Aussenkuehlung / Inside and outside coolant supply  
Kuehlmittelfiltrierung <math>50\mu</math> / coolant filtration <math>50\mu</math>

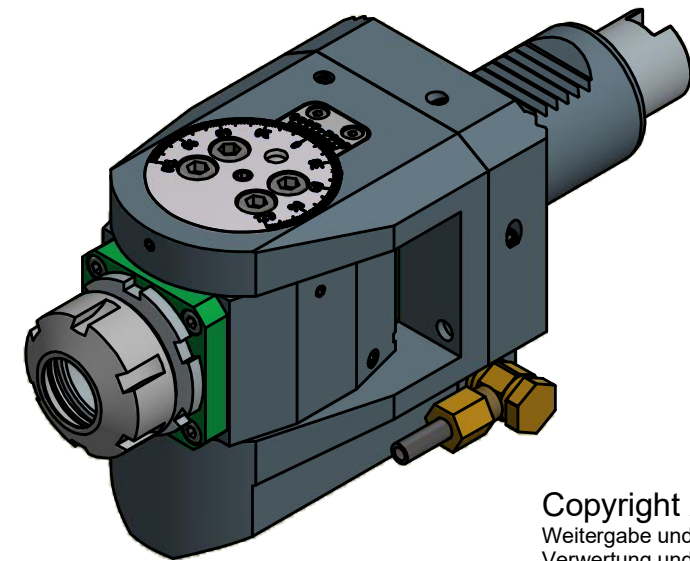

Copyright **EWS Tool Technologies**  
Weitergabe und Vervielfaeltigung dieser Unterlage,  
Verwertung und Mitteilung ihres Inhalts nicht  
gestattet, soweit nicht ausdrecklich zugestanden.  
Zuwiderhandlungen verpflichten zu Schadenersatz.

Bemerkung - Note  
Für Trockenlauf geeignet!  
Use without coolant fluid allowed!

Technische Daten - technical data  
Weight = 5.208 [kg]  
Torque max. (M1/M2) = 20 / 20 [Nm]  
Speed max. (n1/n2) = 6000 / 6000 [1/min]  
Gear ratio (i)=n1:n2 = 1:1  
Pressure (pmax) = 70 [bar]

Benennung - Title  
Schwenkkopf  
Swivel head

**EWS**  
Tool Technologies  
EWS Weigle GmbH & Co. KG  
Maybachstr. 1  
D-73066 UHINGEN  
www.ews-tools.de

Technische Aenderungen vorbehalten!  
Subject to technical modifications!

IDENT: D-EWS-191163

Nr. - No.

63.4025G250RLIKDW



REV: -/-

MNR.

188420

QR