

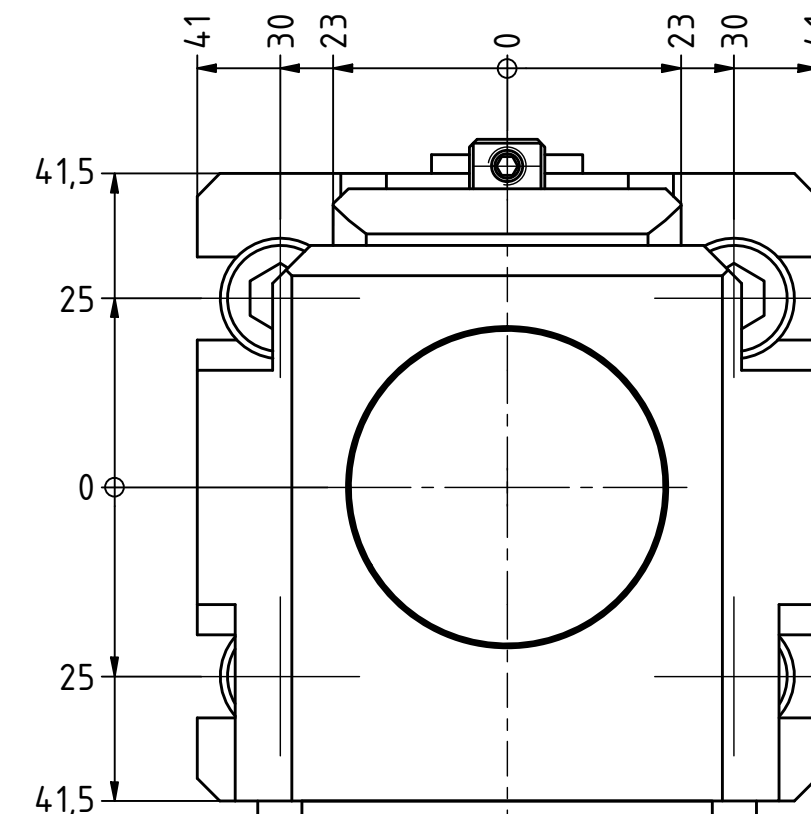

Ceramic Seal

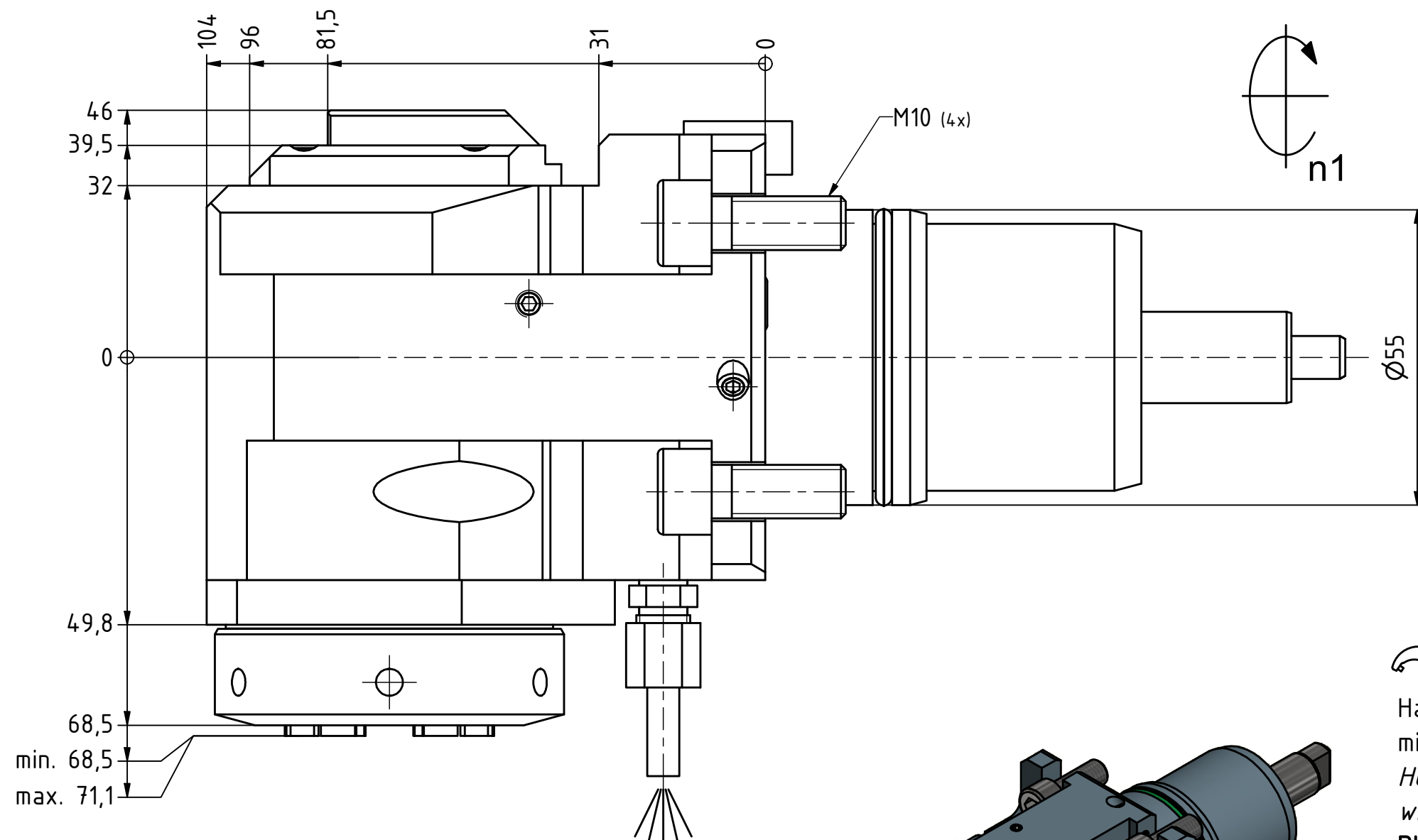

Tech Details



Hakenschlüssel
mit Zapfen
Hook wrench
with fixed pin
DIN1810 B 68x75

Spannzangenschlüssel für
innenliegende Mutter
Clamping wrench for
internal collet
232AX

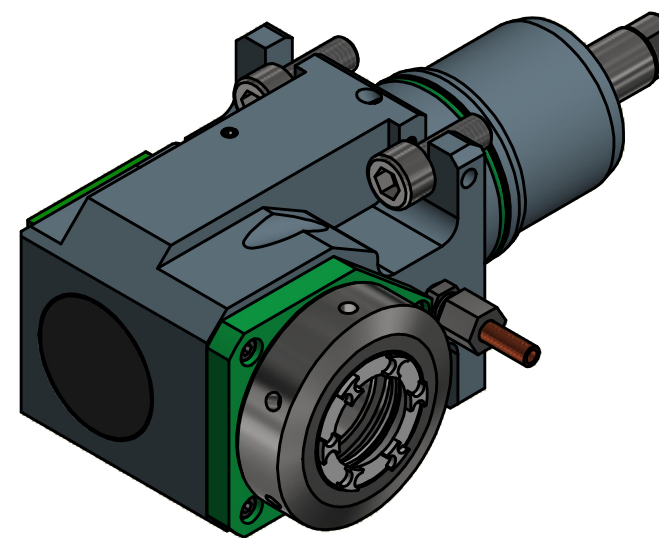

Spannzange / collet ER32 DIN6499
Spannbereich / clamping range: 2,0 - 20,0

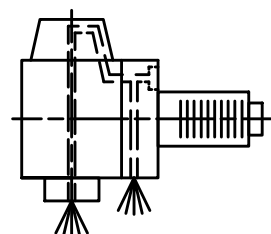

Innen- und Aussenkuehlung / Inside and outside coolant supply
Kuehlmittelfiltrierung=50µ / coolant filtration=50µ

Copyright **EWS Tool Technologies**
Weitergabe und Vervielfaeltigung dieser Unterlage,
Verwertung und Mitteilung ihres Inhalts nicht
gestattet, soweit nicht ausdrecklich zugestanden.
Zuwiderhandlungen verpflichten zu Schadenersatz.

Bemerkung - Note
Für Trockenlauf geeignet!
Use without coolant fluid allowed!

Technische Daten - technical data
Weight = 4.927 [kg]
Torque max. (M1/M2) = 25 / 25 [Nm]
Speed max. (n1/n2) = 6000 / 6000 [1/min]
Gear ratio (i)=n1:n2 = 1:1
Pressure (pmax) = 70 [bar]

Benennung - Title
Radial Bohr und Fräskopf
Radial drilling and milling head



Nr. - No.
60.5532TW10IKDIM

Technische Aenderungen vorbehalten!
Subject to technical modifications!
IDENT: DEWS125073



REV: -/B

MNR.

221953

