

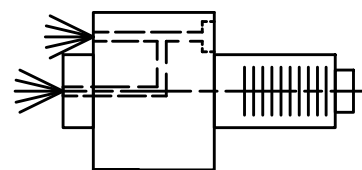

Ceramic Seal

Highspeed

Tech Details

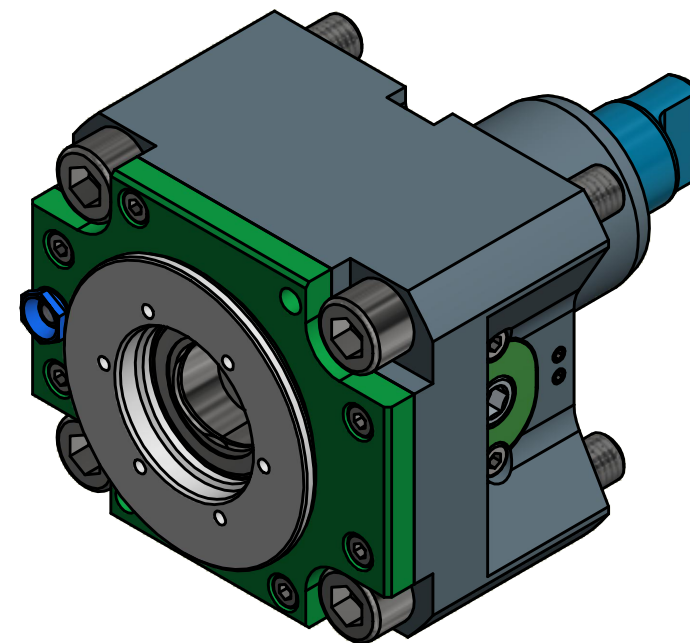
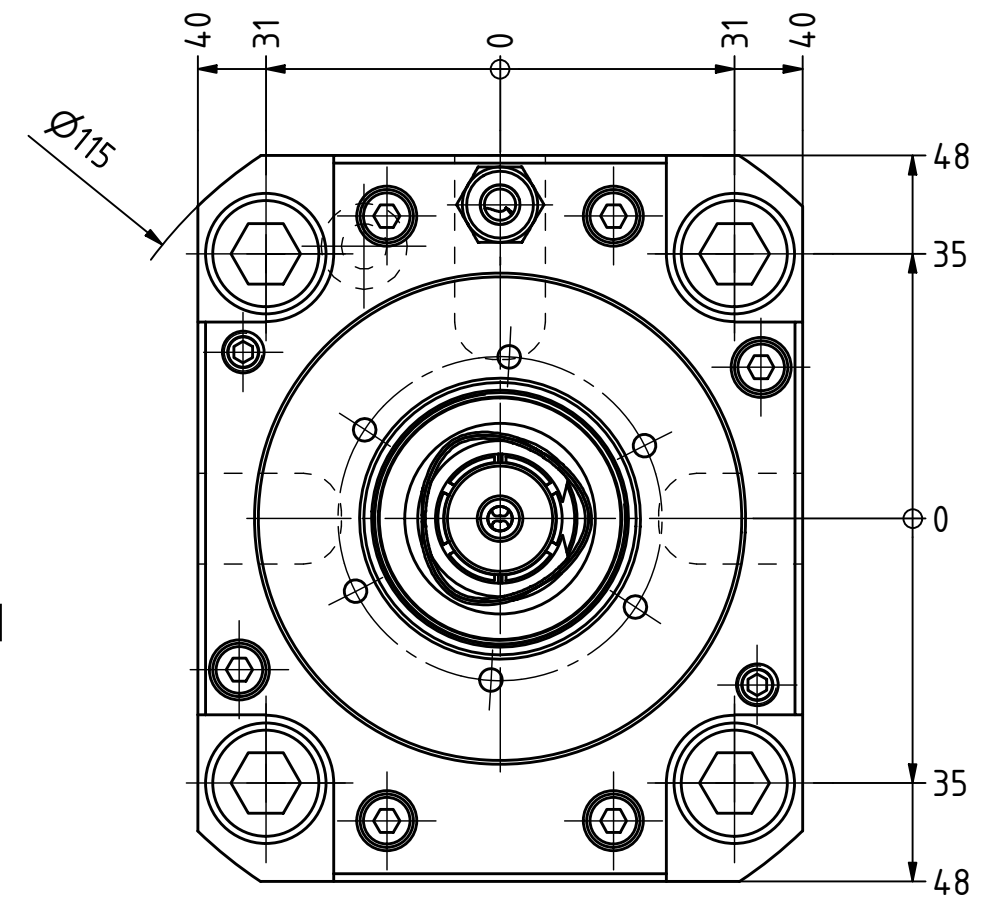
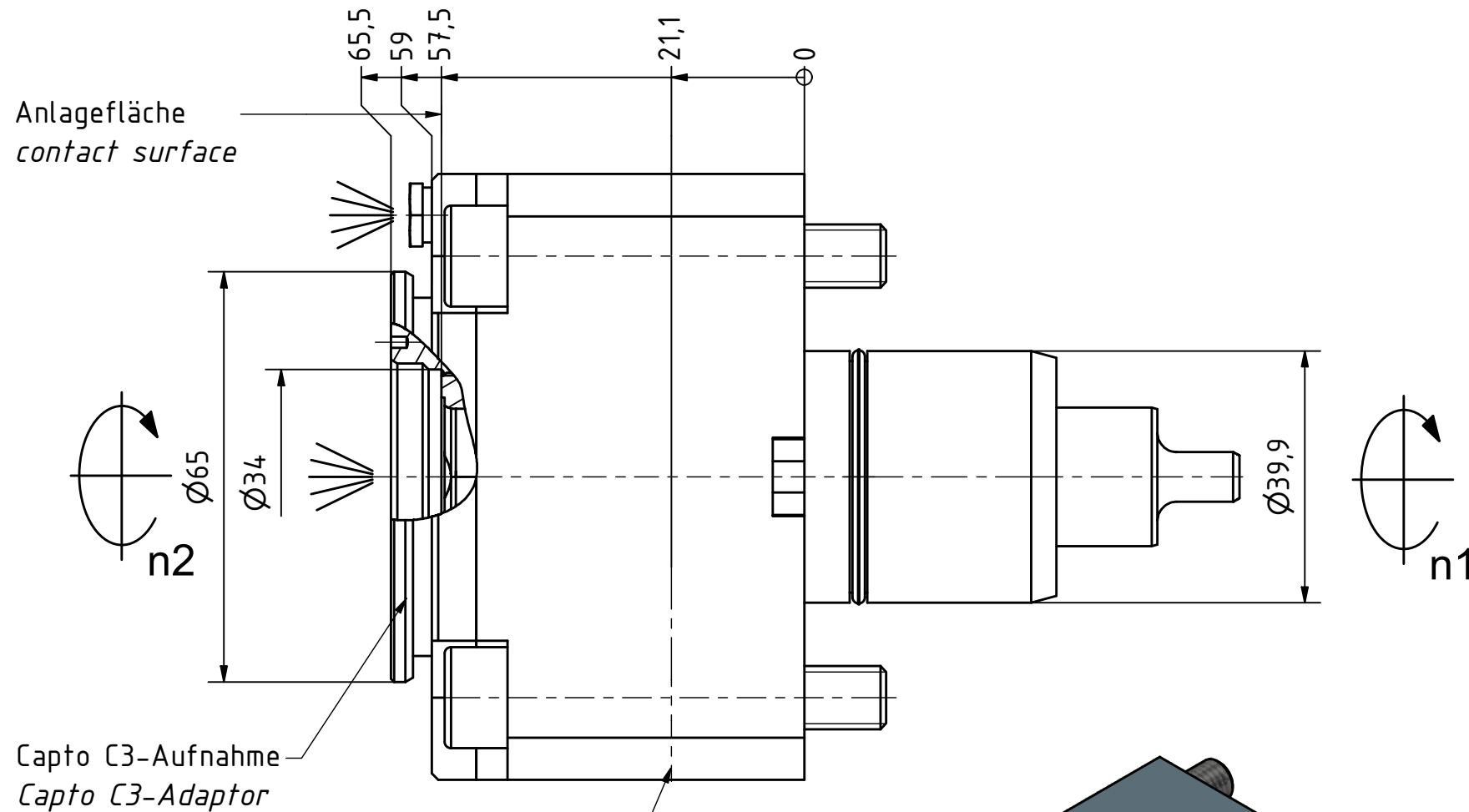

Innen- und Aussenkuehlung / Inside and outside coolant supply
Kuehlmittelfiltrierung<50µ / coolant filtration<50µ

Copyright **EWS Tool Technologies**
Weitergabe und Vervielfaeltigung dieser Unterlage,
Verwertung und Mitteilung ihres Inhalts nicht
gestattet, soweit nicht ausdrucklich zugestanden.
Zuwiderhandlungen verpflichten zu Schadenersatz.

Bemerkung - Note
Für Trockenlauf geeignet!
Use without coolant fluid allowed!

Technische Daten - technical data	
Weight	= 3.362 [kg]
Torque max. (M1/M2)	= 32 / 32 [Nm]
Speed max. (n1/n2)	= 12000 / 12000 [1/min]
Gear ratio (i)=n1:n2	= 1:1
Pressure (pmax)	= 70 [bar]

Benennung - Title
Axial Bohr und Fräskopf
Axial drilling and milling head



Nr. - No.
40.40C3NZIKCHSD12

Technische Aenderungen vorbehalten!
Subject to technical modifications!
IDENT: DEWS145459

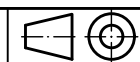

REV: -/A

MNR.
214129

