

Hakenschlüssel
mit Nase
Hook wrench with
nose end
DIN1810 A 58x62

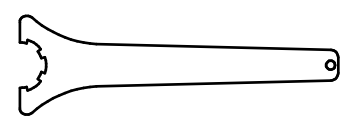

Spannzangenschlüssel
Clamping wrench
225

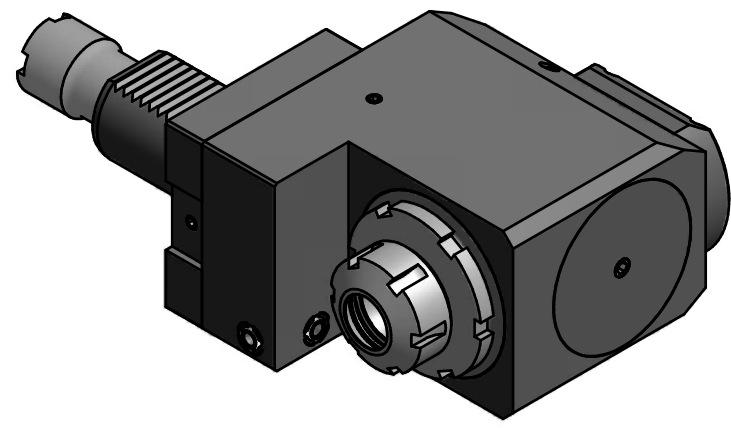

Copyright **EWS Tool Technologies**
Weitergabe und Vervielfaeltigung dieser Unterlage,
Verwertung und Mitteilung ihres Inhalts nicht
gestattet, soweit nicht ausdrecklich zugestanden.
Zuwiderhandlungen verpflichten zu Schadenersatz.

| | | | | | | | |
|------------------|--|---|--|------------|--|-----------------------|------------------------------|
| Bemerkung - Note | Technische Daten - technical data M1 / M2 = 50 / 25 Nm n1 / n2 = 6000 / 12000 1/min i (N1:N2) = 1:2 | Benennung - Title Radial Bohr und Fräskopf, zurückges Radial drill. and mill. head offset | name | date | Technische Aenderungen vorbehalten! Subject to technical modifications! | | |
| | | | drawing | 19.03.2007 | | | Nr. 80.4025LB15LI1 |
| | | | EWS Weigete GmbH & Co. KG Maybachstr. 1 D-73066 Uhingen Tel. +49(0)7161/93040-100 | | MNR: 188199 | IDENT: D-EWS-011536 - | Blatt - page 1 (1) |