

Spannzange / Collet ER16 DIN6499
 Spannbereich / Clamping range: 1,0 - 10,0

Gewindebohrzange / Tapping Collet
 ET-1-16 M1-M6

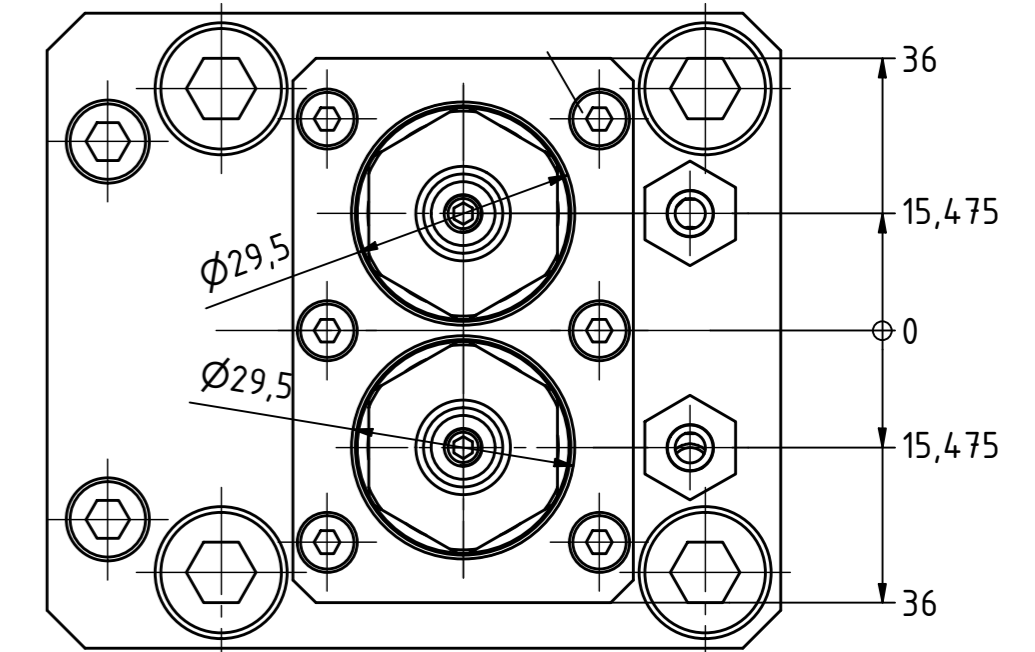
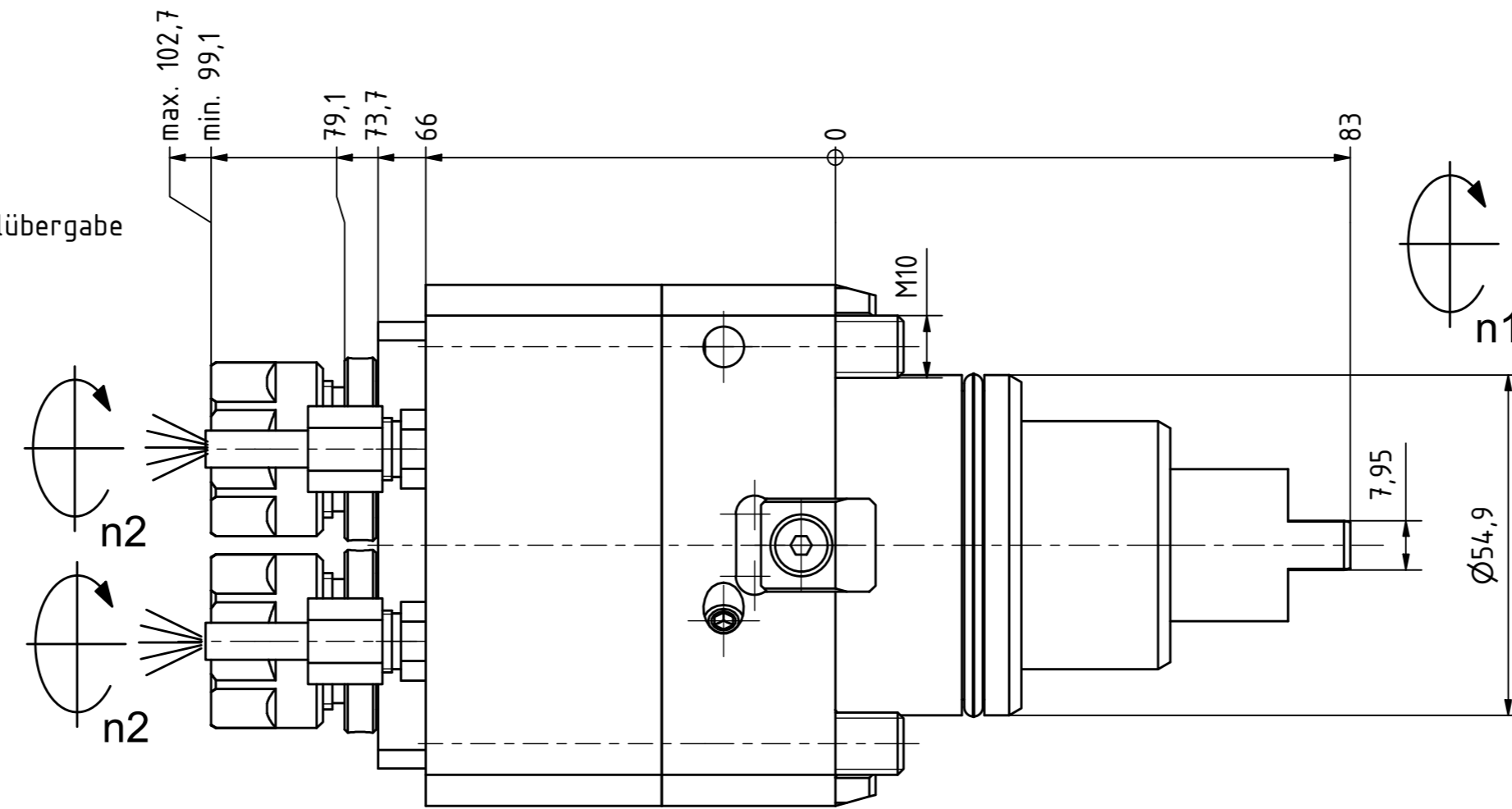
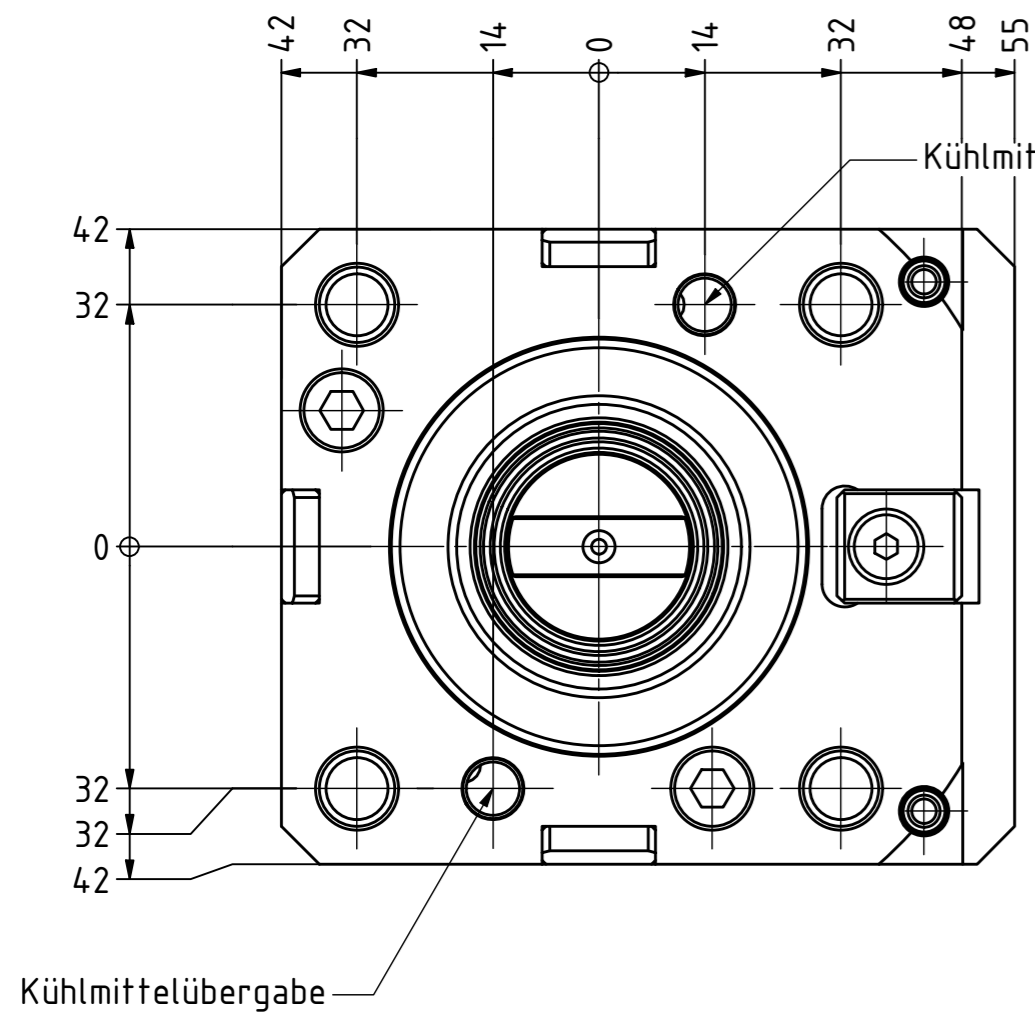

Spannzange / Collet ER16 DIN6499
 Spannbereich / Clamping range: 1,0 - 10,0

Gewindebohrzange / Tapping Collet
 ET-1-16 M1-M6

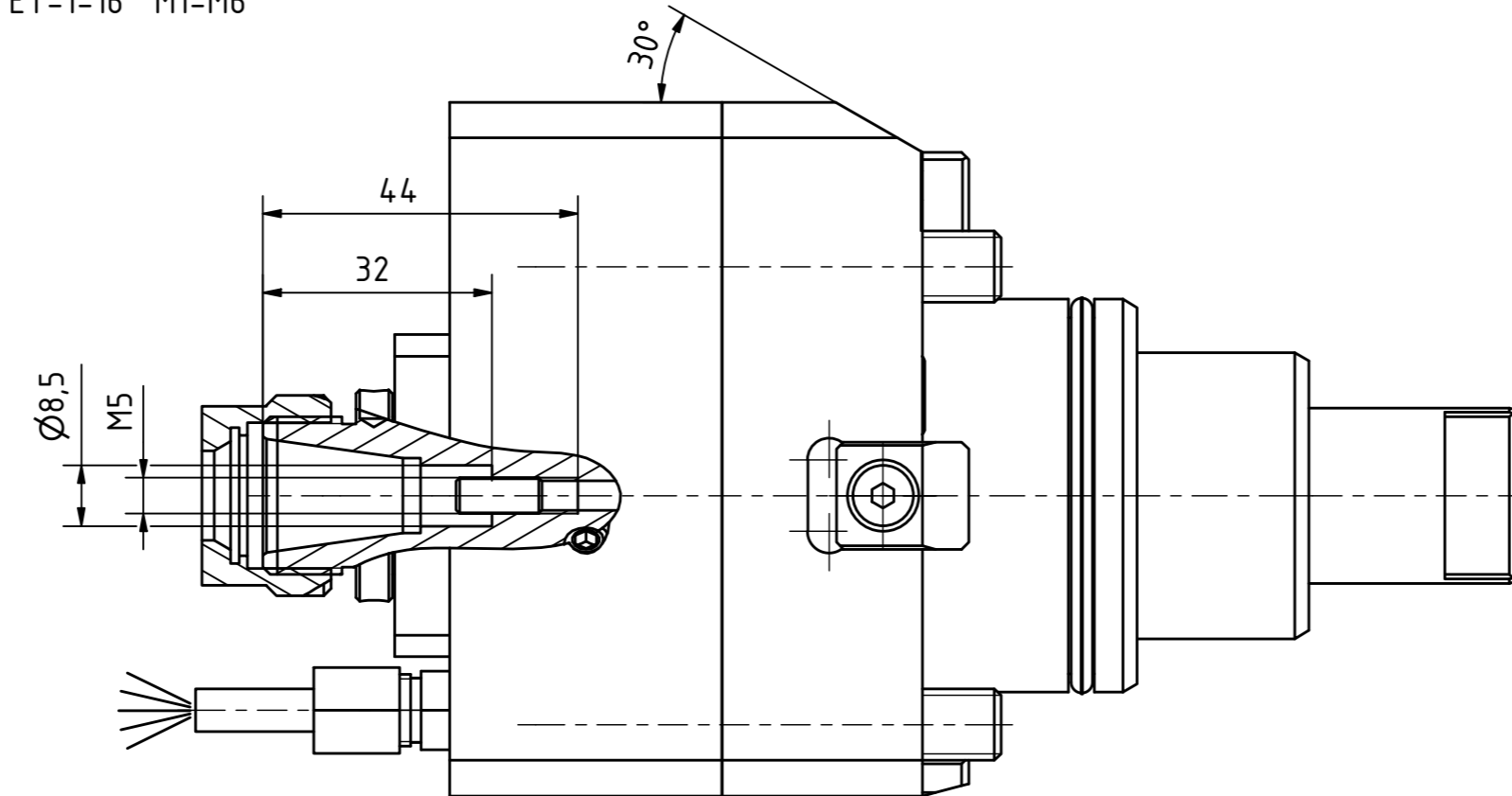

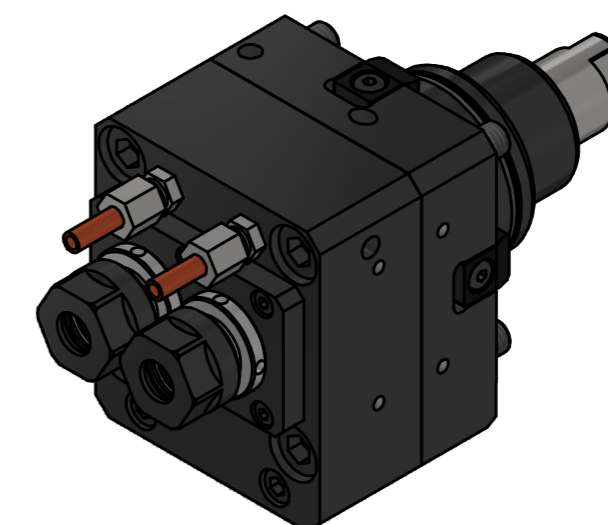

MMS - max. 10 bar
 MQL - max. 10 bar



Hakenschlüssel
 mit Zapfen
 Hook wrench
 with fixed pin
 DIN1810 B 30x32

Copyright **EWS Tool Technologies**
 Weitergabe und Vervielfältigung dieser Unterlage,
 Verwertung und Mitteilung ihres Inhalts nicht
 gestattet, soweit nicht ausdrücklich zugestanden.
 Zuwiderhandlungen verpflichten zu Schadensersatz.

Bemerkung - Note 	Technische Daten - technical data Weight = 4,792 [kg] Torque max. (M1/M2) = 12 / 6 [Nm] Speed max. (n1/n2) = 5231 / 8000 8000 [1/min] Gear ratio (i)=n1:n2 = 1:1,72 1:1,72	Benennung - Title Axial Bohr und Fräskopf <i>Axial drilling and milling head</i>	 EWS Weigle GmbH & Co. KG Maybachstr. 1 D-73066 Ulmringen www.ews-tools.de	Technische Änderungen vorbehalten! Subject to technical modifications! IDENT: DEWS147455 Nr. - No. 4.0.5516DZVL2MMS115TK30.95	 REV: -/B MNR. 188049	
--------------------------	--	---	---	--	--	---