

Spannzange / Collet ER16 DIN6499
 Spannungsbereich / Clamping range: 1,0 - 10,0

Gewindebohrzange / Tapping Collet
 ET-1-16 M1-M6

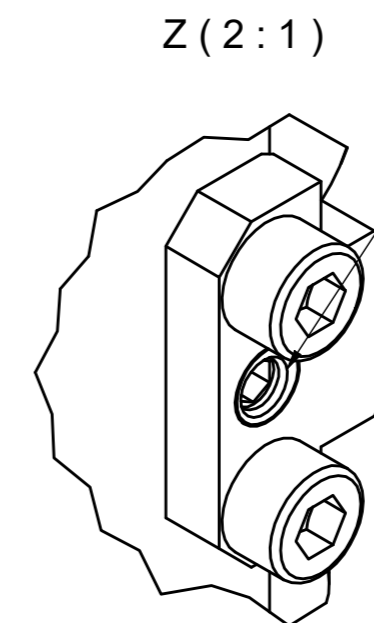

Ausrichtklotz ist über ein Exzenter einstellbar.
 The block is adjustable via eccentric.

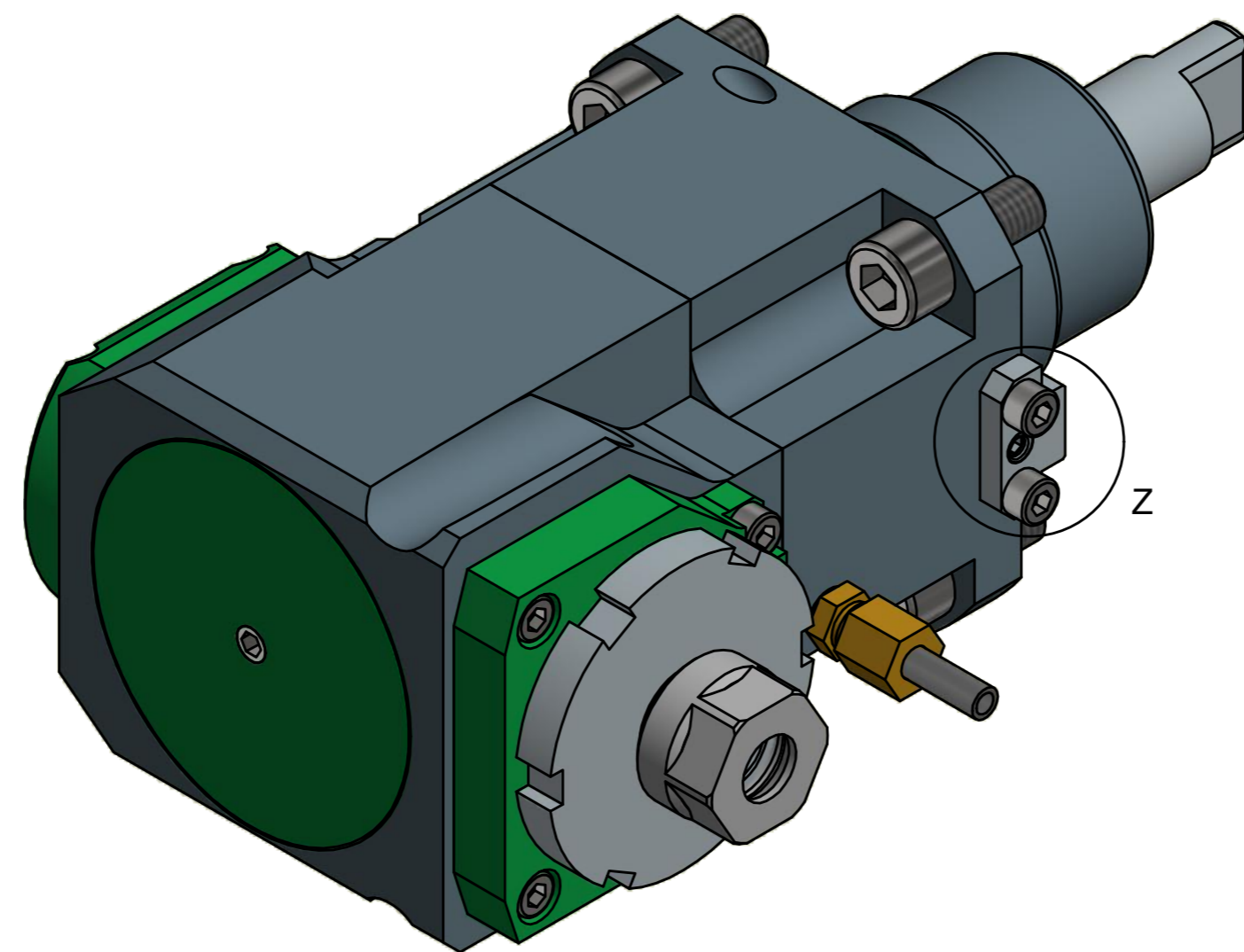
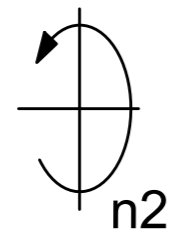
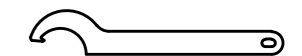

Hakenschlüssel mit Nase
 Hook wrench with nose end
 DIN1810 A 58x62

Copyright **EWS Tool Technologies**
 Weitergabe und Vervielfältigung dieser Unterlage, Verwertung und Mitteilung ihres Inhalts nicht gestattet, soweit nicht ausdrücklich zugestanden. Zuwiderhandlungen verpflichten zu Schadenersatz.

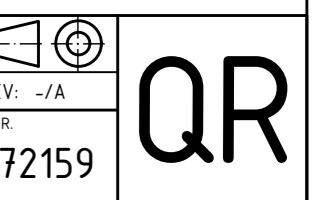
Bemerkung - Note 	Technische Daten - technical data Weight = 6.938 [kg] Torque max. (M1/M2) = 45 / 15 [Nm] Speed max. (n1/n2) = 6000 / 18000 [1/min] Gear ratio (i)=n1:n2 = 1:3	Benennung - Title Radial Bohr und Fräskopf <i>Radial drilling and milling head</i>	 EWS Weigle GmbH & Co. KG Maybachstr. 1 D-73066 Ulm/Ingen www.ews-tools.de Nr. - No. 60.5516BIG1809113X100	Technische Änderungen vorbehalten! Subject to technical modifications! IDENT: DEWS009785 MNR. REV: -/A 172159	
--------------------------	---	---	---	--	---