

Spannzange / collet ER25 DIN6499  
 Spannbereich / clamping range: 1,0 - 16,0

Gewindebohrzange / tapping collet  
 ET-1-25 M3-M12

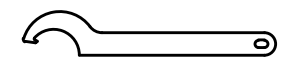
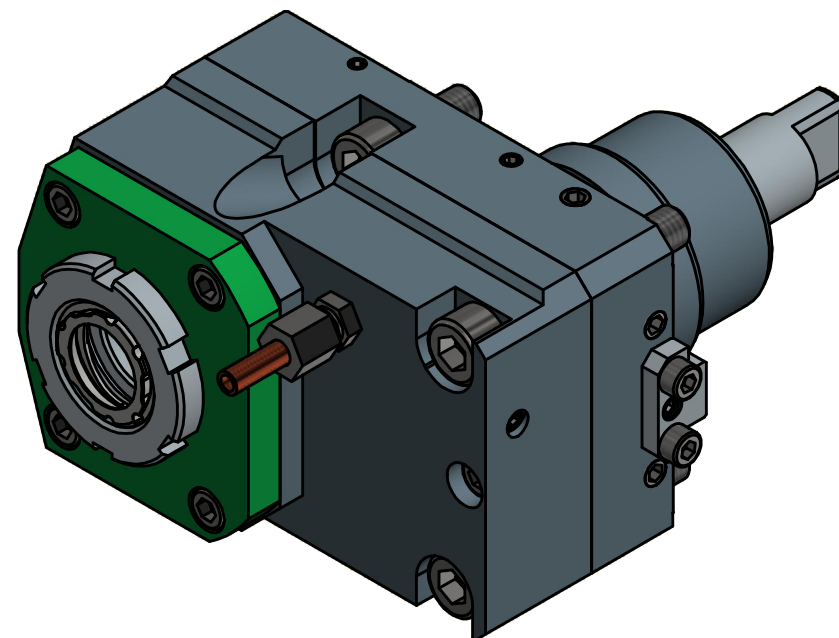

Hakenschlüssel  
 mit Nase  
 Hook wrench with  
 nose end  
 DIN1810 A 45x50

Copyright **EWS Tool Technologies**  
 Weitergabe und Vervielfaeltigung dieser Unterlage,  
 Verwertung und Mitteilung ihres Inhalts nicht  
 gestattet, soweit nicht ausdrecklich zugestanden.  
 Zuwiderhandlungen verpflichten zu Schadenersatz.

Bemerkung - Note

Technische Daten - technical data

Benennung - Title

Weight = 5.551 [kg]  
 Torque max. (M1/M2) = 50 / 25 [Nm]  
 Speed max. (n1/n2) = 6000 / 12000 [1/min]  
 Gear ratio (i)=n1:n2 = 1:2

**Axial Bohr u. Fräskopf achsversetzt**  
**Ax. drill. and mill. head offset**



Nr. - No.

50.5525BIG180911M-S01

Technische Aenderungen vorbehalten!  
 Subject to technical modifications!

IDENT: DEWS045762

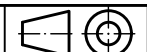

REV: -/A

MNR.

186889

