

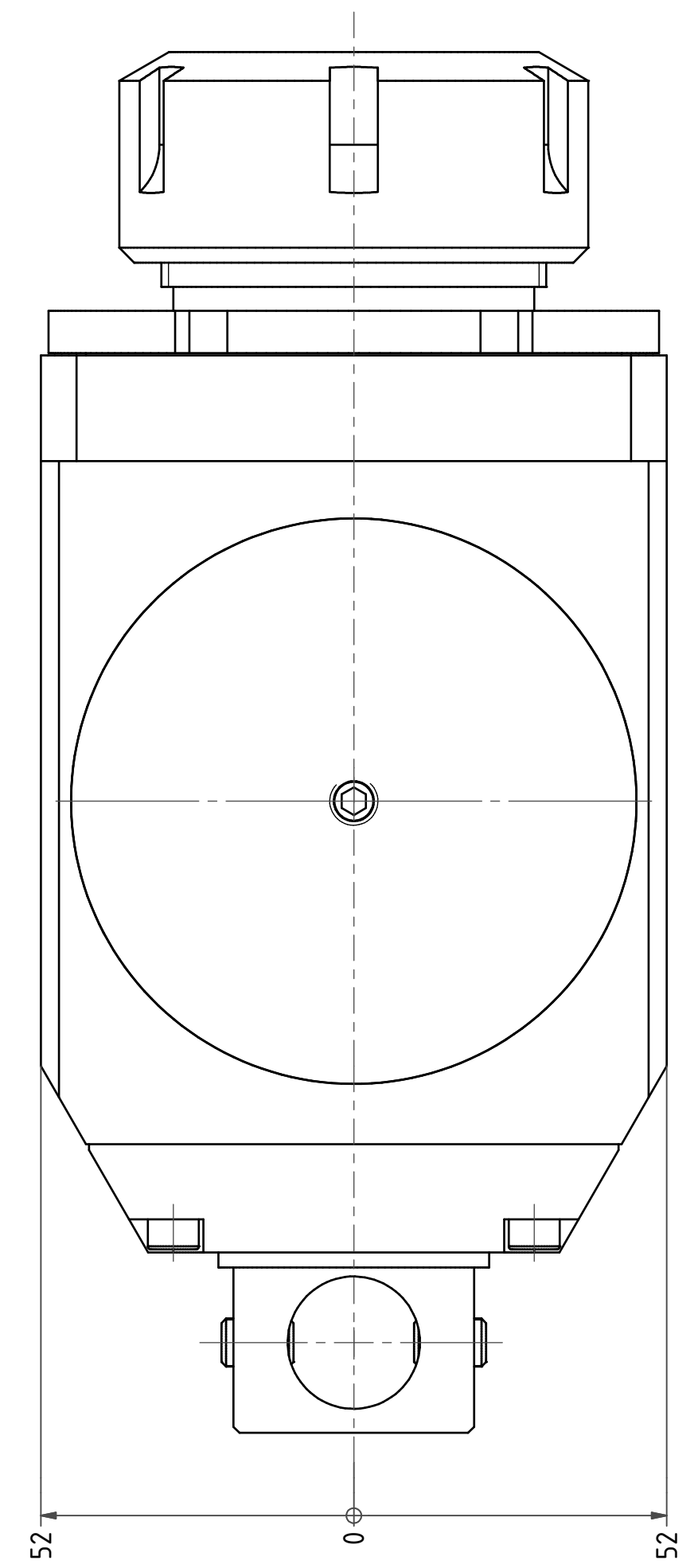

Spannzange / collet ER50 DIN6499
 Spannbereich / clamping range: 6,0 - 34,0

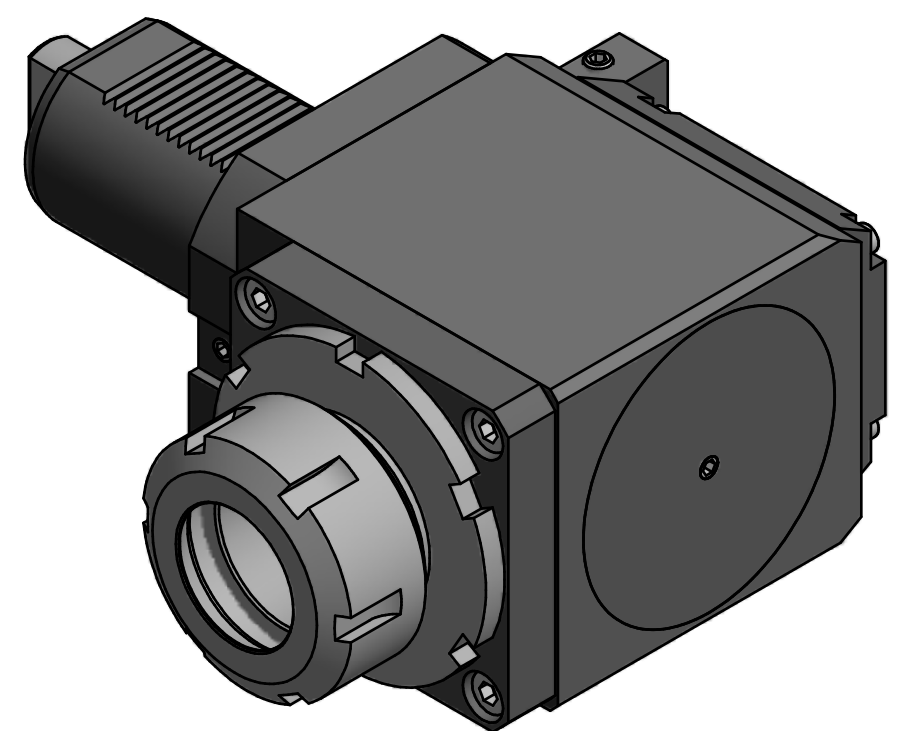
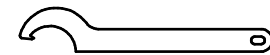
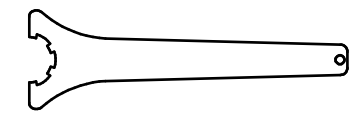

-  Hakenschlüssel mit Nase
Hook wrench with nose end
DIN1810 A 95x100
-  Spannzangenschlüssel
Clamping wrench
250

Copyright **EWS Tool Technologies**
 Weitergabe und Vervielfältigung dieser Unterlage, Verwertung und Mitteilung ihres Inhalts nicht gestattet, soweit nicht ausdrücklich zugestanden. Zuwiderhandlungen verpflichten zu Schadenersatz.

Bemerkung - Note mit Kegelrollenlager with taper roller bearing(s)	Technische Daten - technical data Weight = 14.602 [kg] Torque max. (M1/M2) = 160 / 160 [Nm] Speed max. (n1/n2) = 3000 / 3000 [1/min] Gear ratio (i)=n1:n2 = 1:1	Benennung - Title Radial Bohr und Fräskopf <i>Radial drilling and milling head</i>	<div style="display: flex; justify-content: space-between;"> <div style="text-align: left;">  <p>EWS Weigle GmbH & Co. KG Maybachstr. 1 D-73066 Ulm/ingen www.ews-tools.de</p> </div> <div style="text-align: right;"> <p>Technische Änderungen vorbehalten! Subject to technical modifications!</p> <p>IDENT: D-EWS-217238</p> </div> </div> <div style="display: flex; justify-content: space-between; margin-top: 5px;"> <div style="text-align: left;"> <p>Nr. - No. 60.6050KR1809L</p> </div> <div style="text-align: right;"> <p>REV: -/- MNR. 195693</p> </div> </div>
--	---	---	---

