

Spannzange / collet ER20 DIN6499  
 Spannbereich / clamping range: 1,0 - 13,0

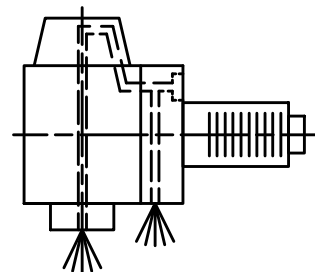

Innen- und Aussenkuehlung / Inside and outside coolant supply  
 Kuehlmittelfiltrierung+50µ / coolant filtration+50µ

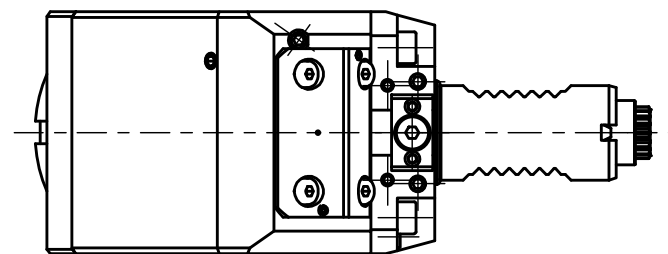

Doppelverzahnung Lizenz Traub  
 double tooth system licence Traub

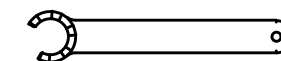
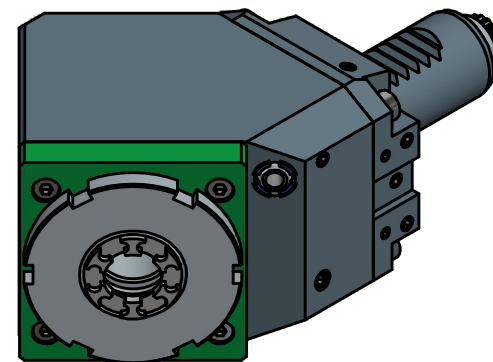

Spannzangenschlüssel für  
 innenliegende Mutter  
 Clamping wrench for  
 internal collet  
 220AX

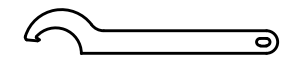

Hakenschlüssel  
 mit Nase  
 Hook wrench with  
 nose end  
 DIN1810 A 58x62

Copyright **EWS Tool Technologies**  
 Weitergabe und Vervielfaeltigung dieser Unterlage,  
 Verwertung und Mitteilung ihres Inhalts nicht  
 gestattet, soweit nicht ausdrecklich zugestanden.  
 Zuwiderhandlungen verpflichten zu Schadenersatz.

Bemerkung - Note  
 Für Trockenlauf geeignet!  
 Use without coolant fluid allowed!

Technische Daten - technical data  
 Weight = 3.024 [kg]  
 Torque max. (M1/M2) = 25 / 25 [Nm]  
 Speed max. (n1/n2) = 8000 / 8000 [1/min]  
 Gear ratio (i)=n1:n2 = 1:1  
 Pressure (pmax) = 70 [bar]

Benennung - Title  
**Radial Bohr und Fräskopf**  
**Radial drilling and milling head**



Nr. - No.  
**60.25205480RLIKDTKW45IM**

Technische Aenderungen vorbehalten!  
 Subject to technical modifications!  
 IDENT: D-EWS-187863

REV: -/-  
 MNR.  
**187020**

