

Spannzange / Collet ER16 DIN6499  
 Spannungsbereich / Clamping range: 1,0 - 10,0

Gewindebohrzange / Tapping Collet  
 ET-1-16 M1-M6

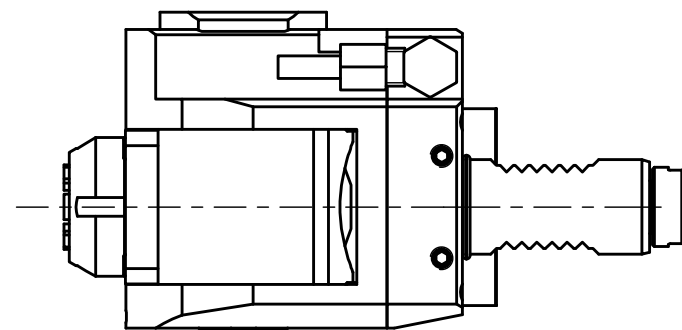

Doppelverzahnung Lizenz Traub  
 double tooth system licence Traub

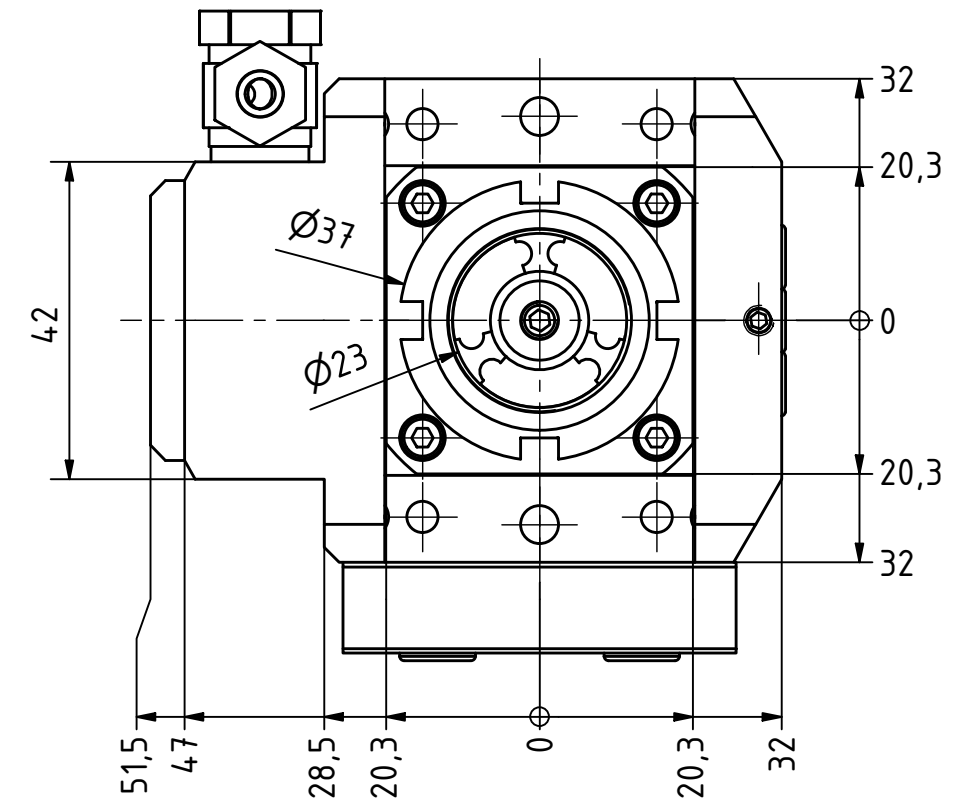
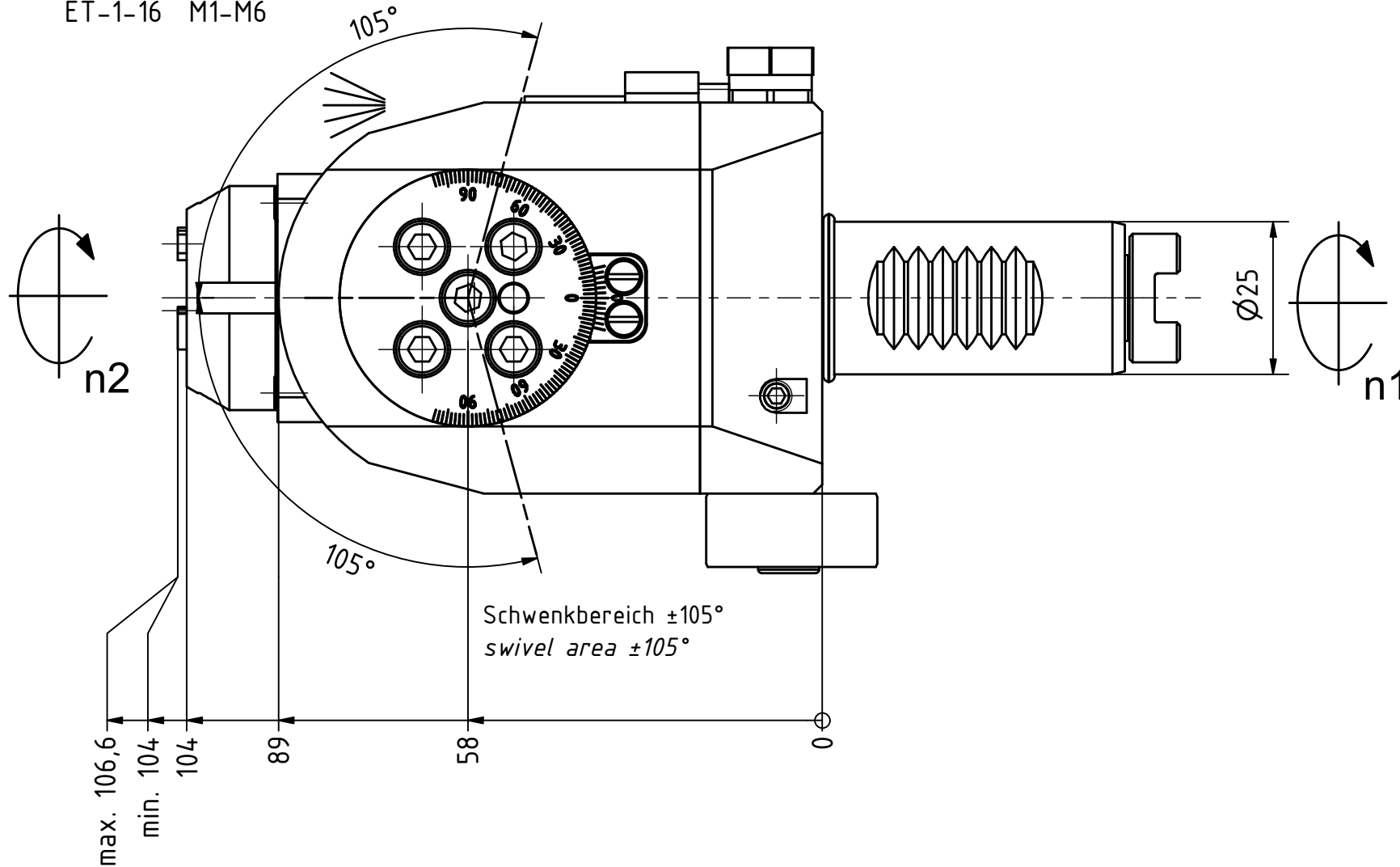
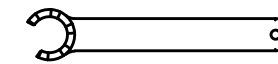
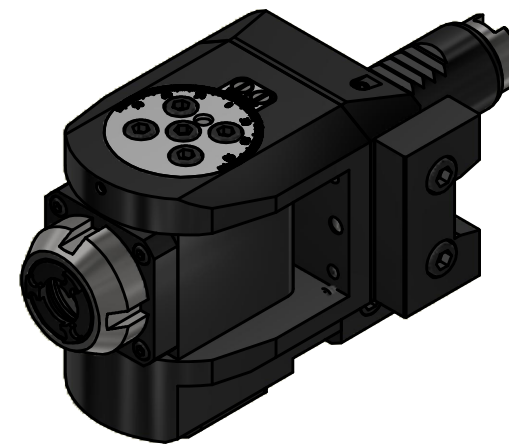

Spannzangenschlüssel für  
 innenliegende Mutter  
 Clamping wrench for  
 internal collet  
 216AX

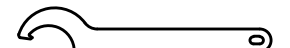

Hakenschlüssel  
 mit Nase  
 Hook wrench with  
 nose end  
 DIN1810 A 36x38

Eine Nachbarstation ist nicht verwendbar!  
 One neighbour station is not useable!

Copyright **EWS Tool Technologies**  
 Weitergabe und Vervielfältigung dieser Unterlage,  
 Verwertung und Mitteilung ihres Inhalts nicht  
 gestattet, soweit nicht ausdrücklich zugestanden.  
 Zuwiderhandlungen verpflichten zu Schadenersatz.

Bemerkung - Note  	Technische Daten - technical data Weight = 2.742 [kg] Torque max. (M1/M2) = 16 / 16 [Nm] Speed max. (n1/n2) = 8000 / 8000 [1/min] Gear ratio (i)=n1:n2 = 1:1	Benennung - Title <b>Schwenkkopf</b> <b>Swivel head</b>	 EWS Weigele GmbH & Co. KG Maybachstr. 1 D-73066 UHINGEN www.ews-tools.de Nr. - No. <b>63.2516G200RLVIM</b>	Technische Änderungen vorbehalten! Subject to technical modifications! IDENT: DEWS257170 MNR. <b>196608</b>	 <b>QR</b>
--------------------------	--	---	---	---	---------------