

Spannzange / collet ER25 DIN6499
 Spannungsbereich / clamping range: 1,0 - 16,0

Gewindebohrzange / tapping collet
 ET-1-25 M3-M10

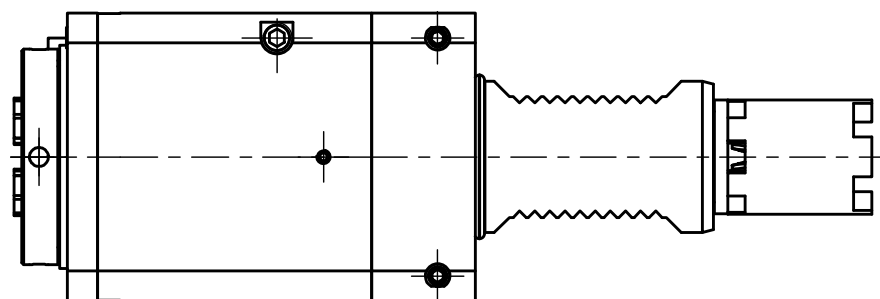

Doppelverzahnung Lizenz Traub
 double tooth system licence Traub

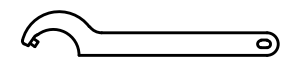
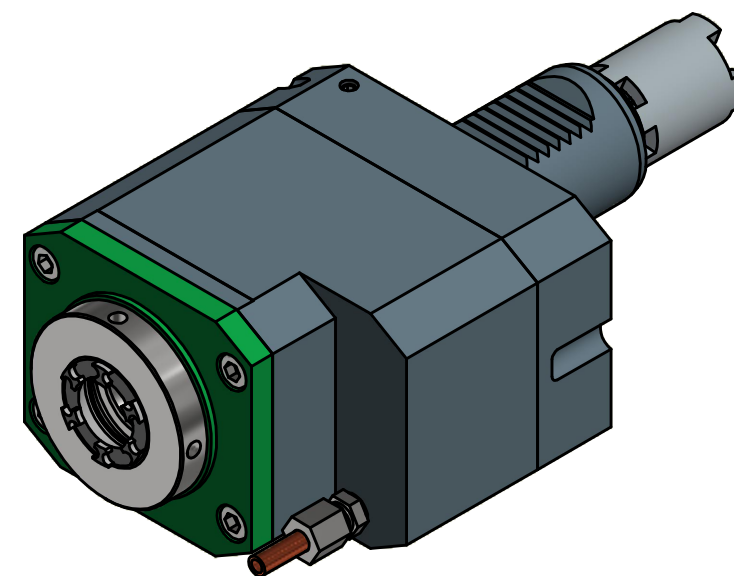

Hakenschlüssel
 mit Zapfen
 Hook wrench
 with fixed pin
 DIN1810 B 58x62

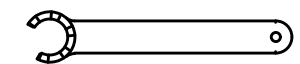

Spannzangenschlüssel für
 innenliegende Mutter
 Clamping wrench for
 internal collet
 225AX

Copyright **EWS Tool Technologies**
 Weitergabe und Vervielfältigung dieser Unterlage,
 Verwertung und Mitteilung ihres Inhalts nicht
 gestattet, soweit nicht ausdrücklich zugestanden.
 Zuwiderhandlungen verpflichten zu Schadenersatz.

Bemerkung - Note

Technische Daten - technical data

Benennung - Title

Weight = 6,443 [kg]
 Torque max. (M1/M2) = 45 / 15 [Nm]
 Speed max. (n1/n2) = 5000 / 15000 [1/min]
 Gear ratio (i)=n1:n2 = 1:3

Axial Bohr und Fräskopf
Axial drilling and milling head



Nr. - No.

40.4025HAASSL20RLI13GLIM

Technische Änderungen vorbehalten!
 Subject to technical modifications!

IDENT: D-EWS-146921

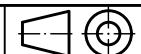

REV: -/A

MNR.

171149

