

Spannzange / collet ER40 DIN6499  
 Spannbereich / clamping range: 3,0 - 26,0

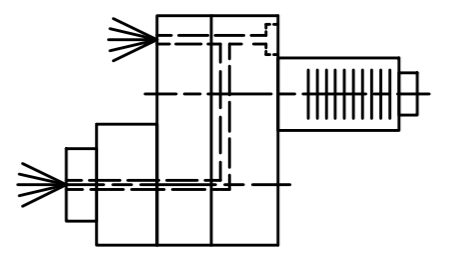
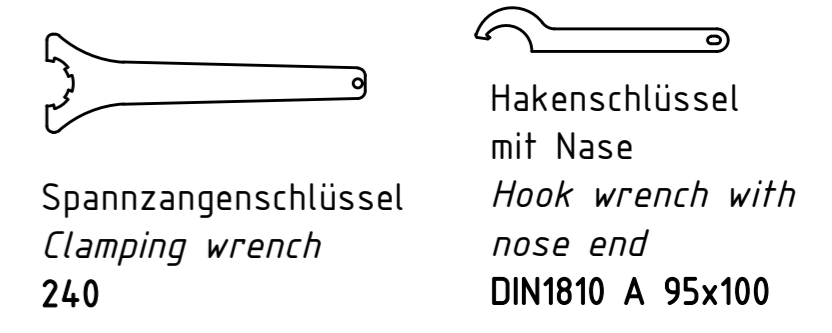
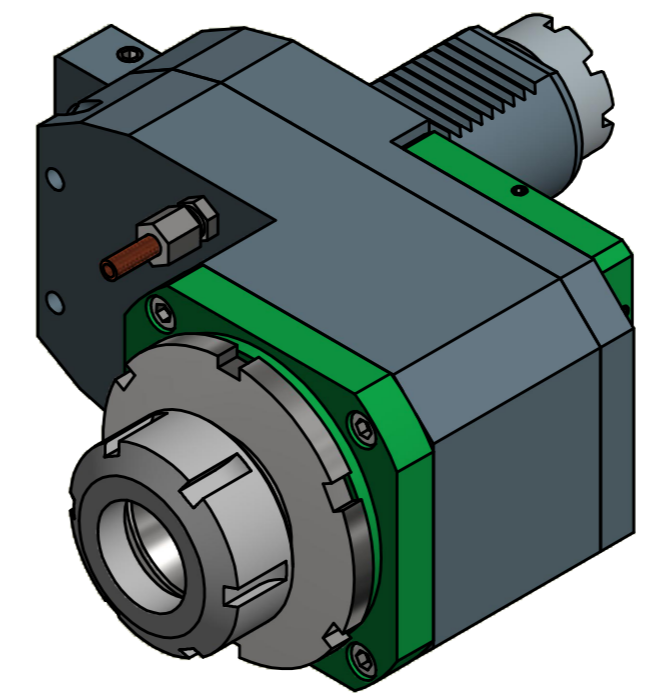

Innen- und Aussenkuehlung / Inside and outside coolant supply  
 Kein Trockenlauf / No dry run  
 Kuehlmittefiltrierung<math>50\mu</math> / coolant filtration<math>50\mu</math>

Bemerkung - Note Nicht ohne Kuehlmitte betreiben! Not for use without coolant-fluid!	Technische Daten - technical data Weight = 11,144 [kg]
	Torque max. (M1/M2) = 100 / 100 [Nm]
	Speed max. (n1/n2) = 4000 / 4000 [1/min]
	Gear ratio (i)=n1:n2 = 1:1
	Pressure (pmax) = 70 [bar]

Benennung - Title  
**Axial Bohr u. Fräskopf achsversetzt**  
**Ax. drill. and mill. head offset**

<b>EWS</b> <small>Tool Technologies</small> EWS Weigle GmbH & Co. KG Maybachstr. 1 D-73066 Uhlingen www.ews-tool.de	Technische Aenderungen vorbehalten! Subject to technical modifications! IDENT: DEWS134060	
	Nr. - No. <b>50.5040TOEMRIK</b>	MNR. <b>195443</b>

Copyright **EWS Tool Technologies**  
 Weitergabe und Vervielfaeltigung dieser Unterlage,  
 Verwertung und Mitteilung ihres Inhalts nicht  
 gestattet, soweit nicht ausdrecklich zugestanden.  
 Zuwiderhandlungen verpflichten zu Schadenersatz.