

Spannzange / collet ER40 DIN6499
Spannbereich / clamping range: 3,0 - 26,0

Gewindebohrzange / tapping collet
ET-1-40 M6-M16

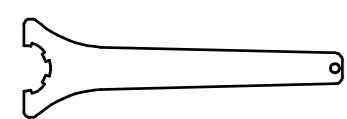

Spannzangenschlüssel
Clamping wrench
240

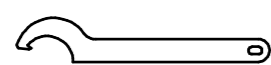

Hakenschlüssel
mit Nase
Hook wrench with
nose end
DIN1810 A 68x75

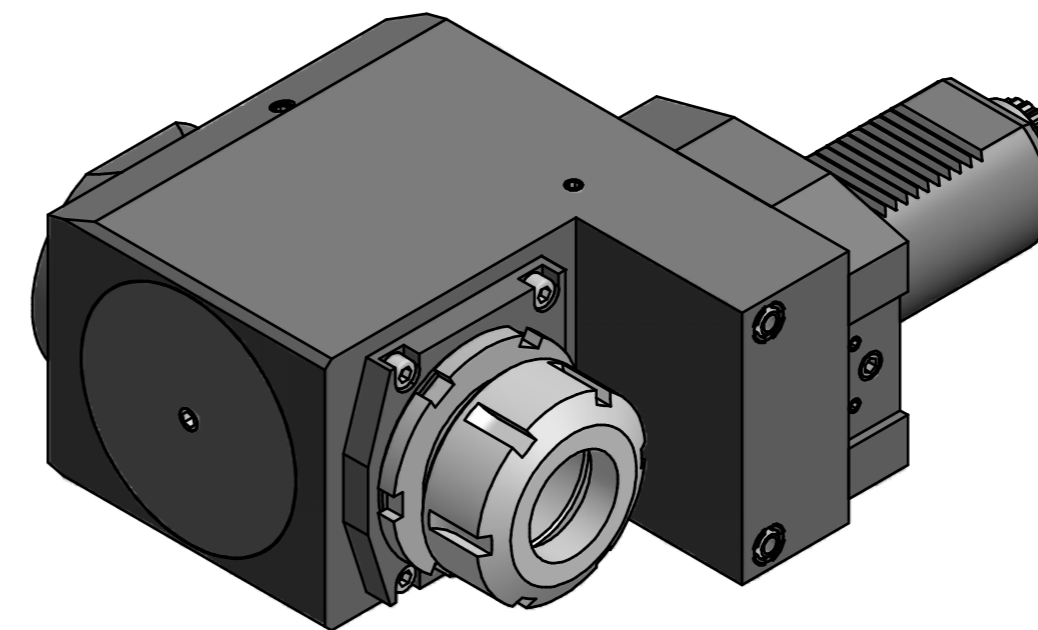

Copyright **EWS Tool Technologies**
Weitergabe und Vervielfältigung dieser Unterlage,
Verwertung und Mitteilung ihres Inhalts nicht
gestattet, soweit nicht ausdrücklich zugestanden.
Zuwendungen verpflichten zu Schadenersatz.

Bemerkung - Note	Technische Daten - Technical data		Benennung - Title	name	date	Technische Änderungen vorbehalten! Subject to technical modifications!	
	M ₁ / M ₂ = 100 / 50 Nm	n ₁ / n ₂ = 4000 / 8000 1/min					i (N ₁ :N ₂) = 1:2
			Radial Bohr und Fräskopf. zurückges		EWS Weigete GmbH & Co. KG Maybachstr. 1 D-73066 Ulm/ingen Tel. +49(0)7161/93040-10		DIN A2
			Radial drill. and mill. head offset		File: 80.5040548011_OUT.idw		Blatt - page 1 (1)