

Spannzange / collet ER20 DIN6499
 Spannbereich / clamping range: 1,0 - 13,0

Gewindebohrzange / tapping collet
 ET-1-20 M2-M6

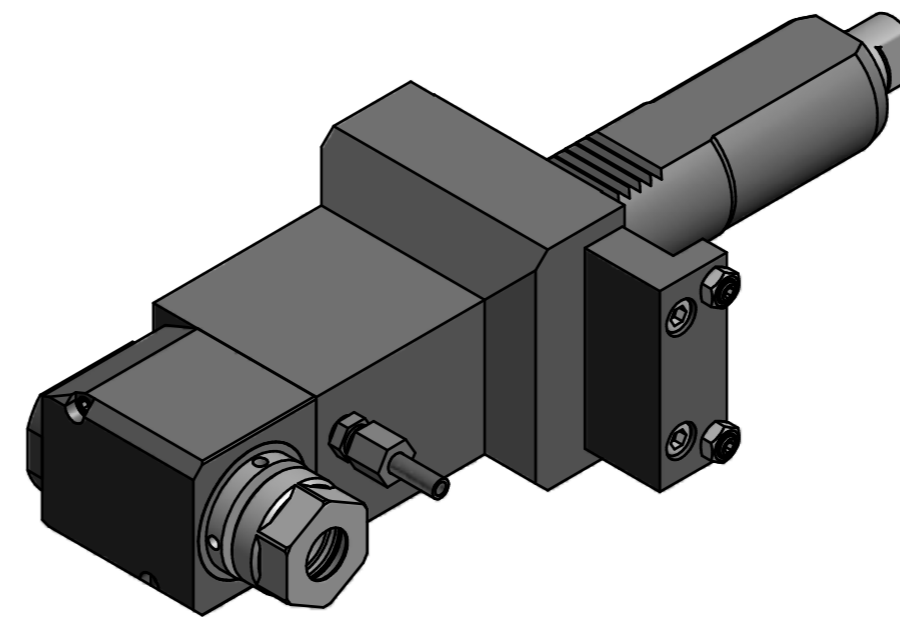

 Hakenschlüssel
 mit Zapfen
 Hook wrench
 with fixed pin
 DIN1810 B 34x36

Copyright **EWS Tool Technologies**
 Weitergabe und Vervielfältigung dieser Unterlage,
 Verwertung und Mitteilung ihres Inhalts nicht
 gestattet, soweit nicht ausdrücklich zugestanden.
 Zuwiderhandlungen verpflichten zu Schadenersatz.

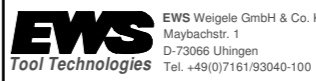
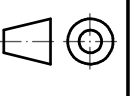
Bemerkung - Note	Technische Daten - technical data		Benennung - Title	name M. Simoniello date 14.07.2014 Technische Änderungen vorbehalten! Subject to technical modifications! Nr. 60.4020VTCRX130-BG20 MNR: 171039 IDENT: D-EWS-159376 - Blatt - page 1 (1)
	M ₁ / M ₂ = 10 / 10 Nm n ₁ / n ₂ = 6000 / 6000 1/min i (N ₁ :N ₂) = 1:1			
 EWS Weigte GmbH & Co. KG Maybachstr. 1 D-72096 Ulm/lingen Tel. +49(0)7161/93040-100			 DIN A2	