

Spannzange / collet ER40 DIN6499
 Spannbereich / clamping range: 3,0 - 26,0

Gewindebohrzange / tapping collet
 ET-1-40 M6-M16

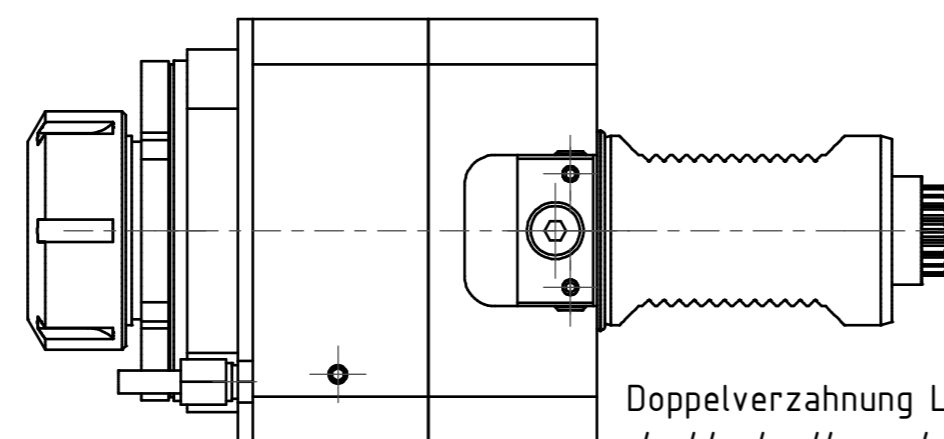

Doppelverzahnung Lizenz Traub
 double tooth system licence Traub

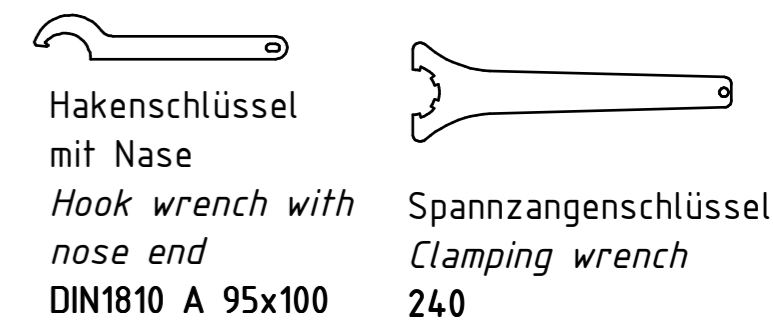
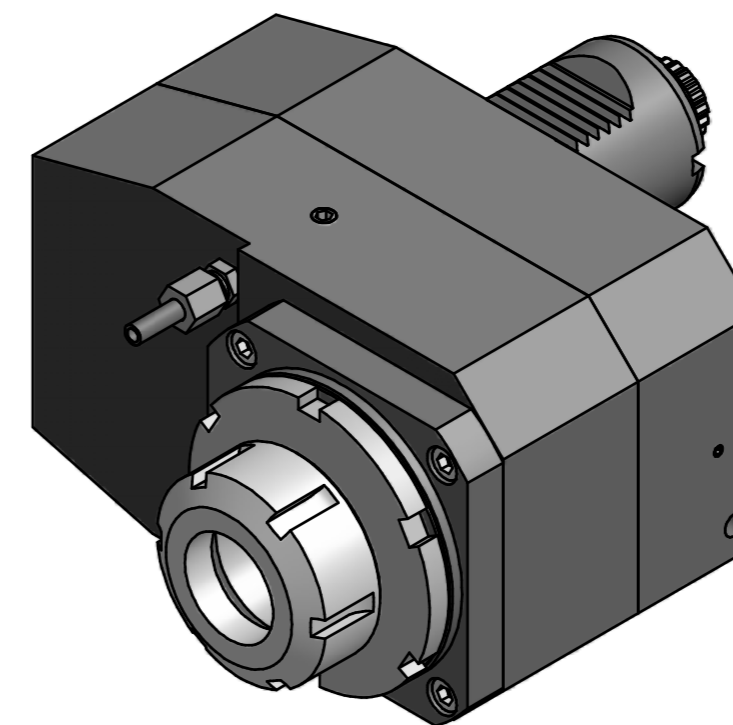

Hakenschlüssel
 mit Nase
 Hook wrench with
 nose end
 DIN1810 A 95x100

Spannzangenschlüssel
 Clamping wrench
 240

Copyright **EWS Tool Technologies**
 Weitergabe und Vervielfältigung dieser Unterlage,
 Verwertung und Mitteilung ihres Inhalts nicht
 gestattet, soweit nicht ausdrücklich zugestanden.
 Zuwiderhandlungen verpflichten zu Schadenersatz.

Bemerkung - Note	Technische Daten - technical data		Benennung - Title	name date Technische Änderungen vorbehalten! Subject to technical modifications! Nr. 50.50405480RL11 MNR: 165186 IDENT: D-EWS-132664 - Blatt - page 1 (1)
	M ₁ / M ₂ = 100 / 50 Nm n ₁ / n ₂ = 4000 / 8000 1/min i (N ₁ :N ₂) = 1:2			

