

6 | 5 | 4 | 3 | 2 | 1

D
C
B
A

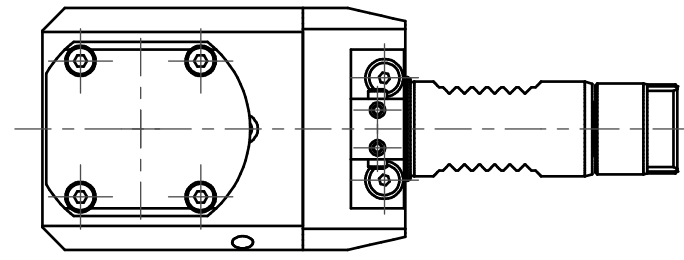

Doppelverzahnung Lizenz Traub
double tooth system licence Traub

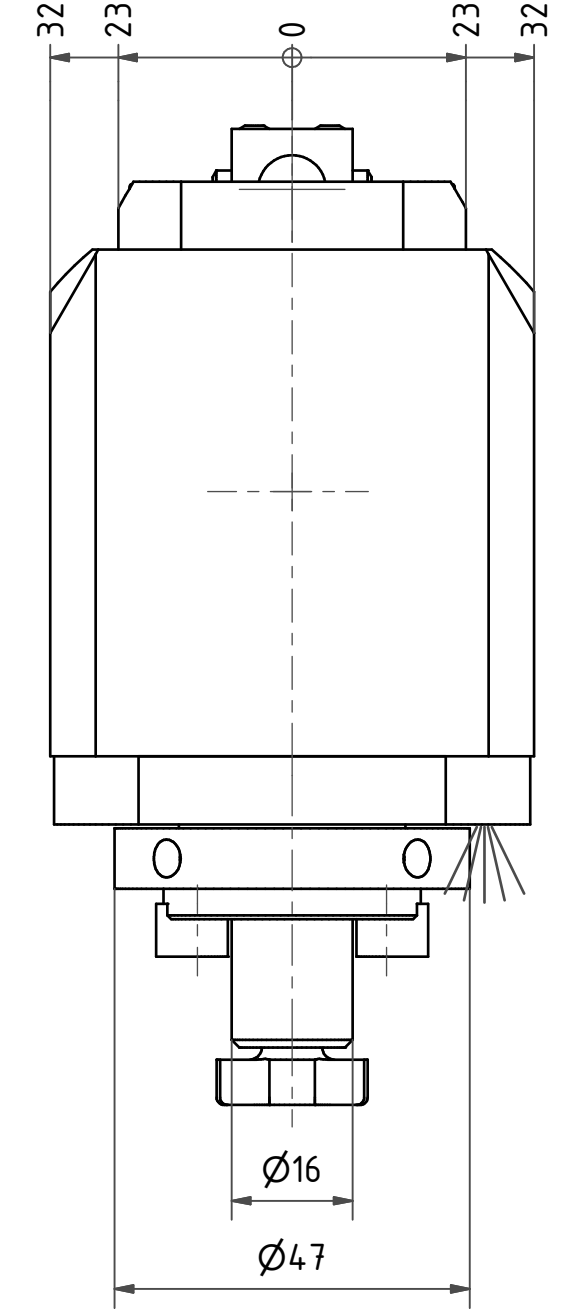
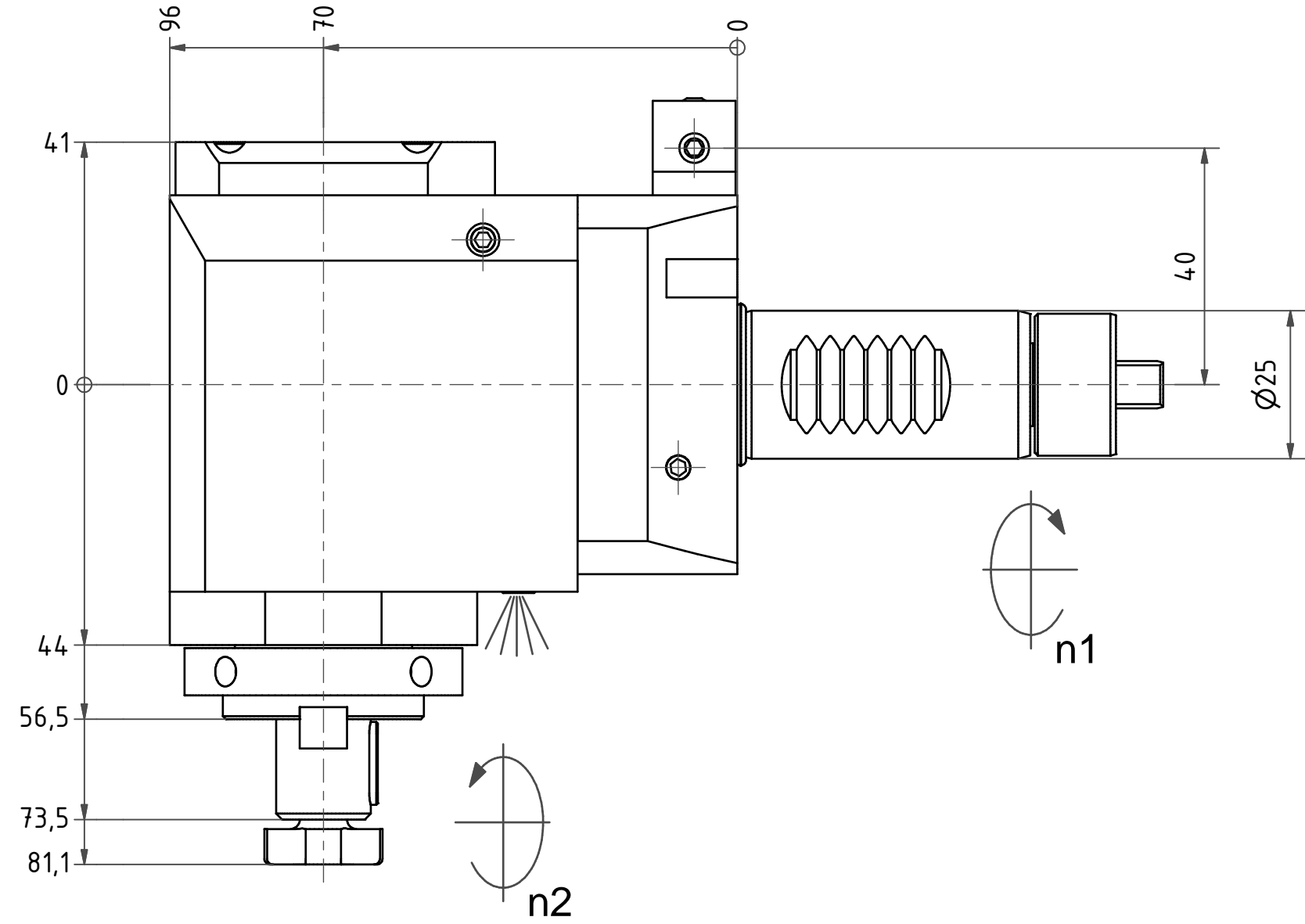
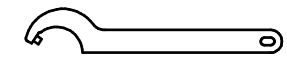
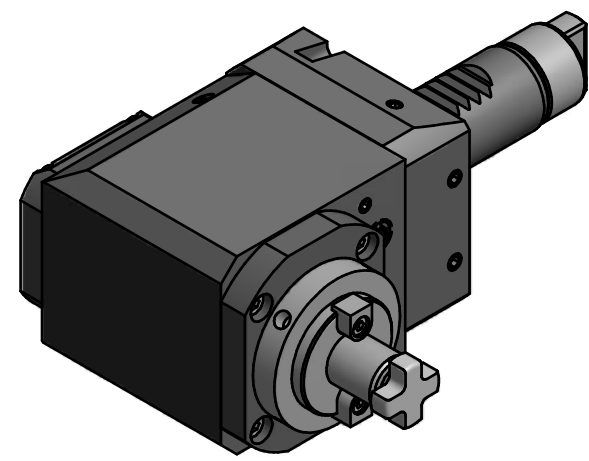

Hakenschlüssel
mit Zapfen
Hook wrench
with fixed pin
DIN1810 B 45x50

Copyright **EWS Tool Technologies**
Weitergabe und Vervielfaeltigung dieser Unterlage,
Verwertung und Mitteilung ihres Inhalts nicht
gestattet, soweit nicht ausdrecklich zugestanden.
Zuwiderhandlungen verpflichten zu Schadenersatz.

Bemerkung - Note	Technische Daten - technical data	Benennung - Title	name	date	Technische Aenderungen vorbehalten! Subject to technical modifications!	
	M1 / M2 = 25 / 25 Nm n1 / n2 = 6000 / 6000 1/min i (N1:N2) = 1:1					
				EWS Weigete GmbH & Co. KG Maybachstr. 1 D-73066 Uhingen Tel. +49(0)7161/93040-100	MNR: 171000 IDENT: D-EWS-146375 A	Blatt - page 1 (1)

6 | 5 | 4 | 3 | 2 | 1