

Doppelverzahnung Lizenz Traub
double tooth system licence Traub

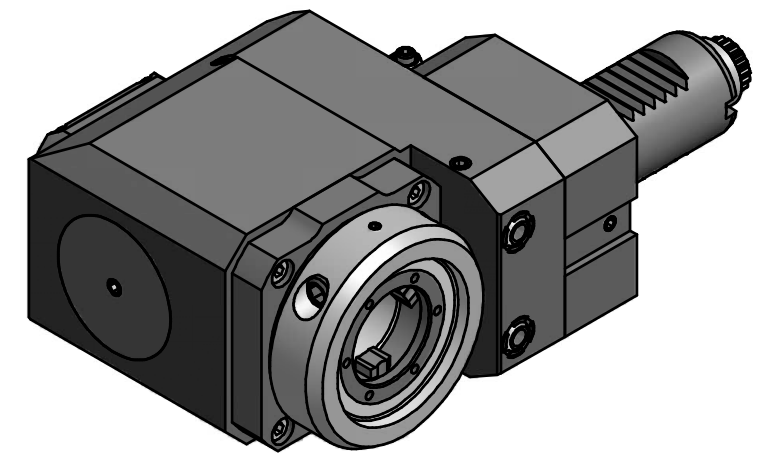

Copyright **EWS Tool Technologies**
Weitergabe und Vervielfältigung dieser Unterlage,
Verwertung und Mitteilung ihres Inhalts nicht
gestattet, soweit nicht ausdrücklich zugestanden.
Zu widerhandlungen verpflichten zu Schadenersatz.

Bemerkung - Note mit Kegelrollenlager with taper roller bearing(s)	Technische Daten - technical data $M1 / M2 = 20 / 40 \text{ Nm}$ $n1 / n2 = 6000 / 3000 \text{ 1/min}$ $i (N1:N2) = 2:1$	Benennung - Title Radial Bohr und Fräskopf. zurückges Radial drill. and mill. head offset	<table border="1"> <tr> <th>name</th> <th>date</th> </tr> <tr> <td>Theiss</td> <td>07.11.2013</td> </tr> </table>	name	date	Theiss	07.11.2013	Technische Aenderungen vorbehalten! Subject to technical modifications! Nr. 80.30VX3KRGT300RLI2 MNR: 165771 IDENT: D-EWS-146466 - Blatt - page 1 (1)
name	date							
Theiss	07.11.2013							

