

Trifix Anzugsdrehmoment 25 Nm
 Trifix clamping torque 25 Nm

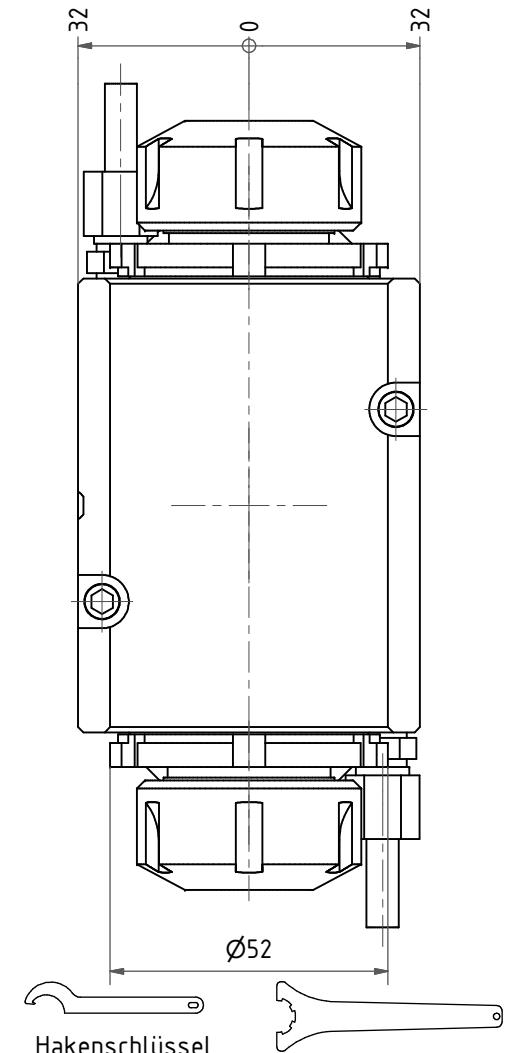

Hakenschlüssel
 mit Nase
 Hook wrench with
 nose end
 DIN1810 A 52x55



Spannzangenschlüssel
 Clamping wrench
 225

Copyright **EWS Tool Technologies**
 Weitergabe und Vervielfältigung dieser Unterlage,
 Verwertung und Mitteilung ihres Inhalts nicht
 gestattet, soweit nicht ausdrücklich zugestanden.
 Zuwiderhandlungen verpflichten zu Schadenersatz.

Spannzange / collet ER25 DIN6499
 Spannungsbereich / clamping range: 1,0 - 16,0

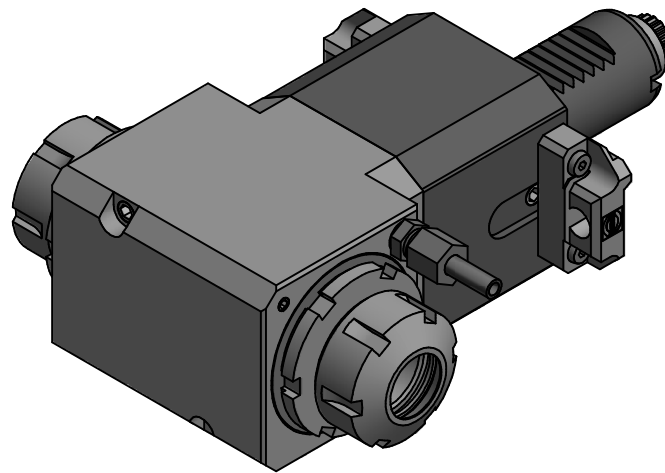
Gewindebohrzange / tapping collet
 ET-1-25 M3-M10



Bemerkung - Note	Technische Daten - technical data Weight = 4.460 [kg] Torque max. (M1/M2) = 25 / 25 [Nm] Speed max. (n1/n2) = 12000 / 12000 [1/min] Gear ratio (i)=n1:n2 = 1:1	Benennung - Title Radial Bohr und Fräskopf Radial drilling and milling head	 EWS Weigelt GmbH & Co. KG Maybachstr. 1 D-73066 Ulm/ingen www.ews-tools.de	Technische Änderungen vorbehalten! Subject to technical modifications! IDENT: DEWS003167	 REV: -/A MNR.	
			Nr. - No. 60.3025LDCTXTFHS12	170648		