

Spannzange / collet ER40 DIN6499
 Spannbereich / clamping range: 3,0 - 26,0

Gewindebohrzange / tapping collet
 ET-1-40 M6-M16

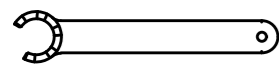

Spannzangenschlüssel für
 innenliegende Mutter
 Clamping wrench for
 internal collet
 240AX

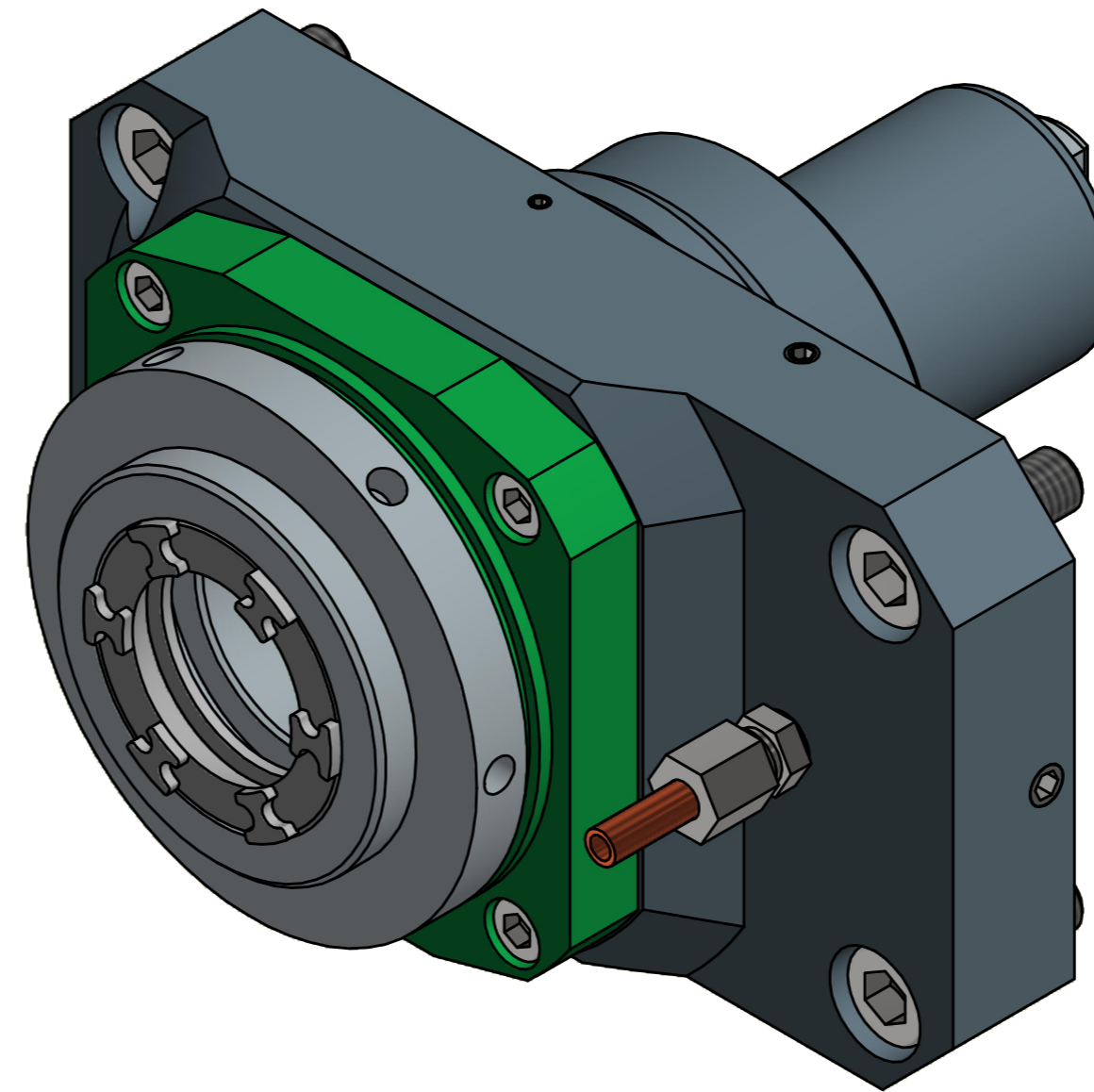
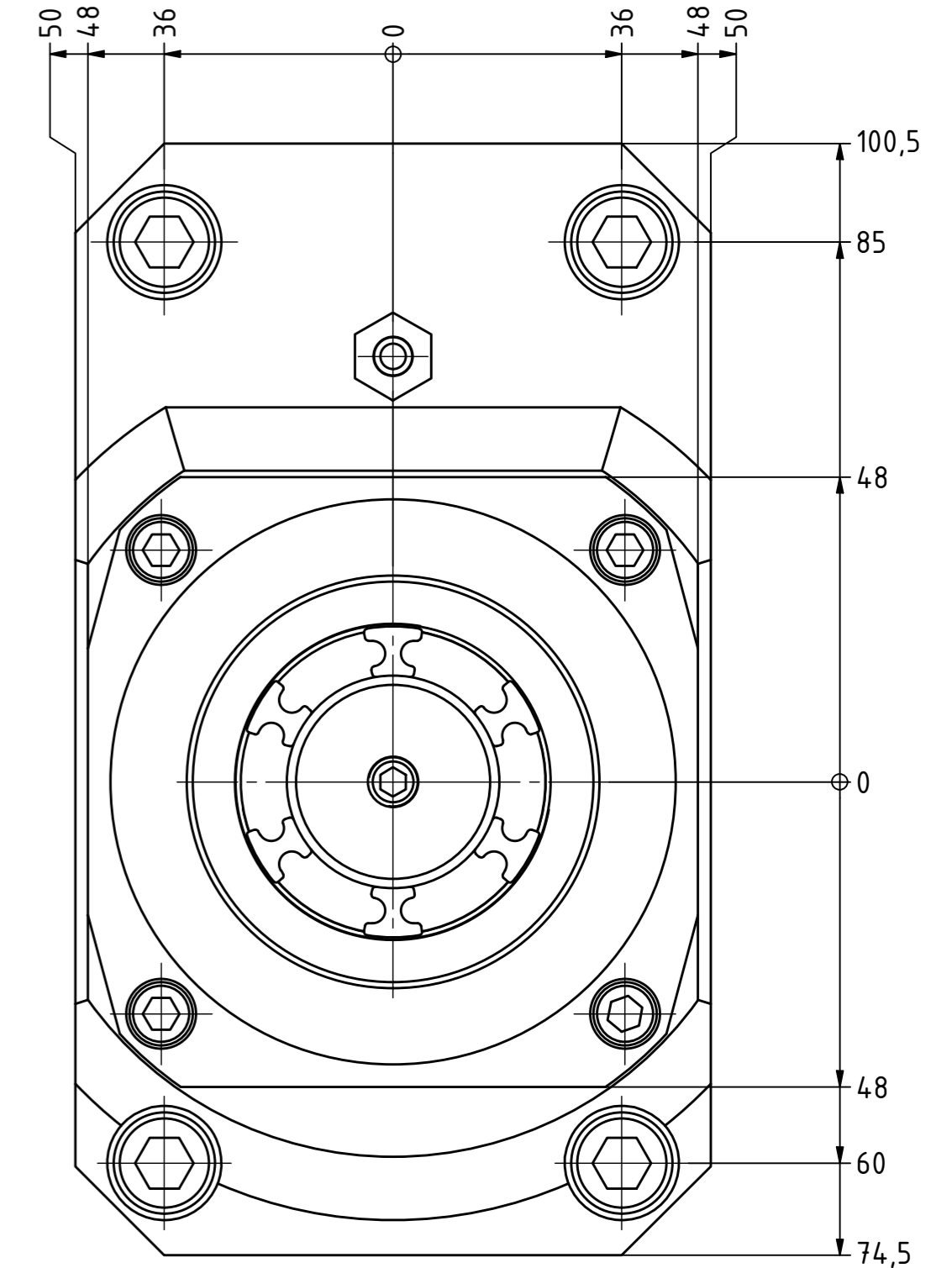
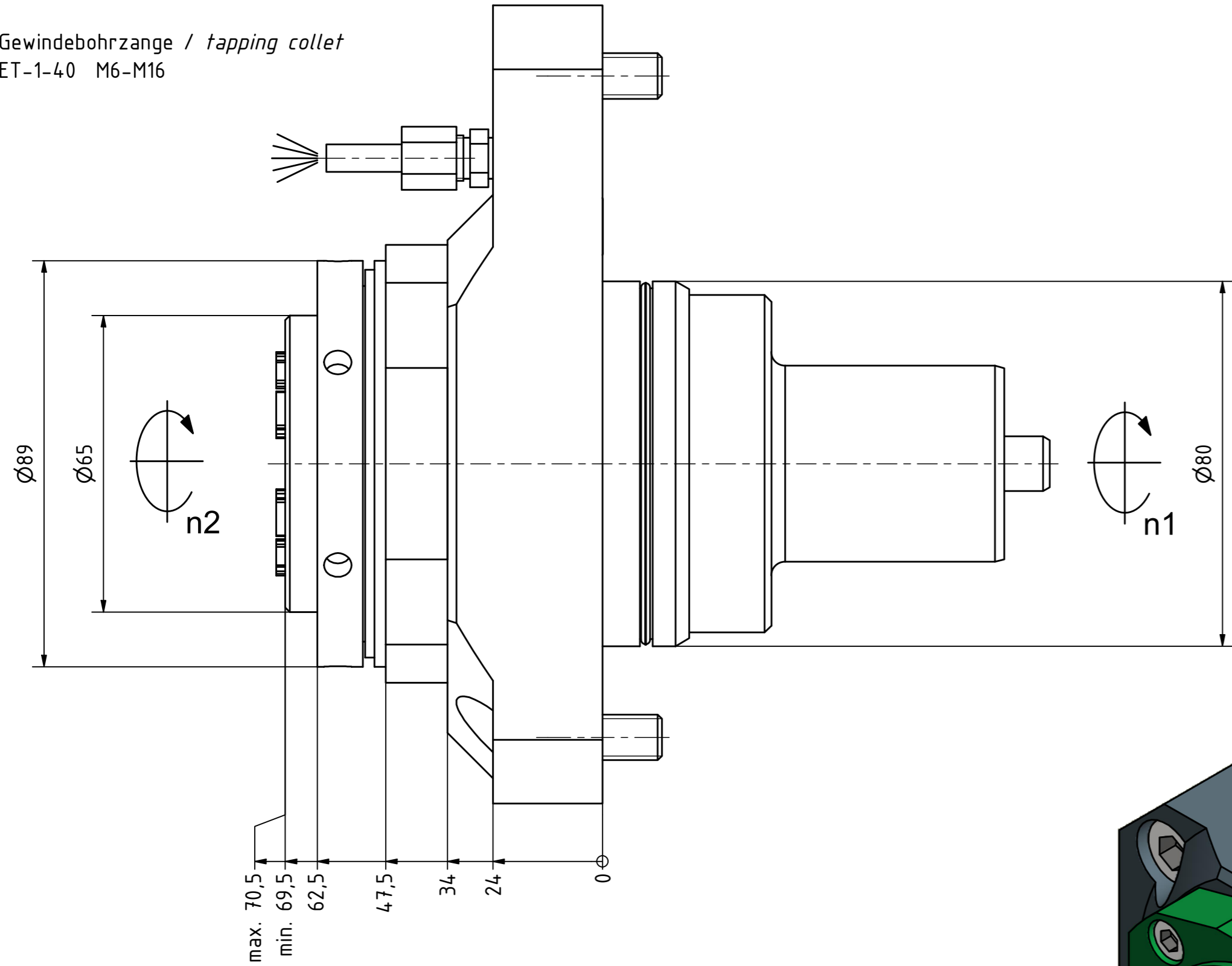
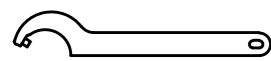

Hakenschlüssel
 mit Zapfen
 Hook wrench
 with fixed pin
 DIN1810 B 80x90

Copyright **EWS Tool Technologies**
 Weitergabe und Vervielfältigung dieser Unterlage,
 Verwertung und Mitteilung ihres Inhalts nicht
 gestattet, soweit nicht ausdrücklich zugestanden.
 Zuwiderhandlungen verpflichten zu Schadenersatz.

Bemerkung - Note	Technische Daten - technical data Weight = 6.726 [kg] Torque max. (M1/M2) = 100 / 100 [Nm] Speed max. (n1/n2) = 6000 / 6000 [1/min] Gear ratio (i)=n1:n2 = 1:1	Benennung - Title Axial Bohr und Fräskopf Axial drilling and milling head	EWS Tool Technologies EWS Weigle GmbH & Co. KG Maybachstr. 1 D-73066 Ulm/ingen www.ews-tools.de	Technische Änderungen vorbehalten! Subject to technical modifications! IDENT: D-EWS-139578 REV: -/- MNR.	Nr. - No. 40.8040QSMBMTIM 158528 QR
------------------	--	--	--	--	--