

Winkelausrichtung & CD-ROM
in Lieferung enthalten!
Angle adjusting & CD-ROM
included in delivery!

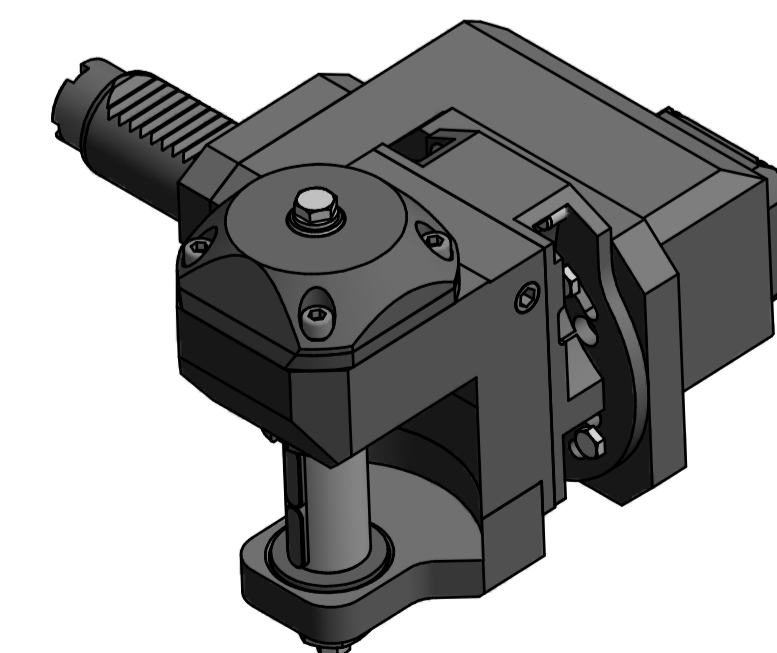

Copyright **EWS Tool Technologies**
Weitergabe und Vervielfältigung dieser Unterlage,
Verwertung und Mitteilung ihres Inhalts nicht
gestattet, soweit nicht ausdrücklich zugestanden.
Zu widerhandlungen verpflichten zu Schadenersatz.

Bemerkung - Note

Technische Daten - technical data
Weight = 7,746 [kg]
Torque max. (M1/M2) = 20 / 60 [Nm]
Speed max. (n1/n2) = 6000 / 2000 [1/min]
Gear ratio (i)=n1:n2 = 3:1

Benennung - Title

Radial Scheibenfräserkopf versetzt
Saw milling spindle offset



EWS Werkzeug GmbH & Co. KG
Rudolfstr. 1
D-72084 Stuttgart
www.ews.de

Technische Änderungen vorbehalten!
Subject to technical modifications!
IDENT: D-EWS-200604

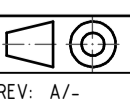

REV: A/-

84.3022LB10L13TKWMB43

182967

