

Spannzange / collet ER25 DIN6499  
Spannbereich / clamping range: 1,0 - 16,0

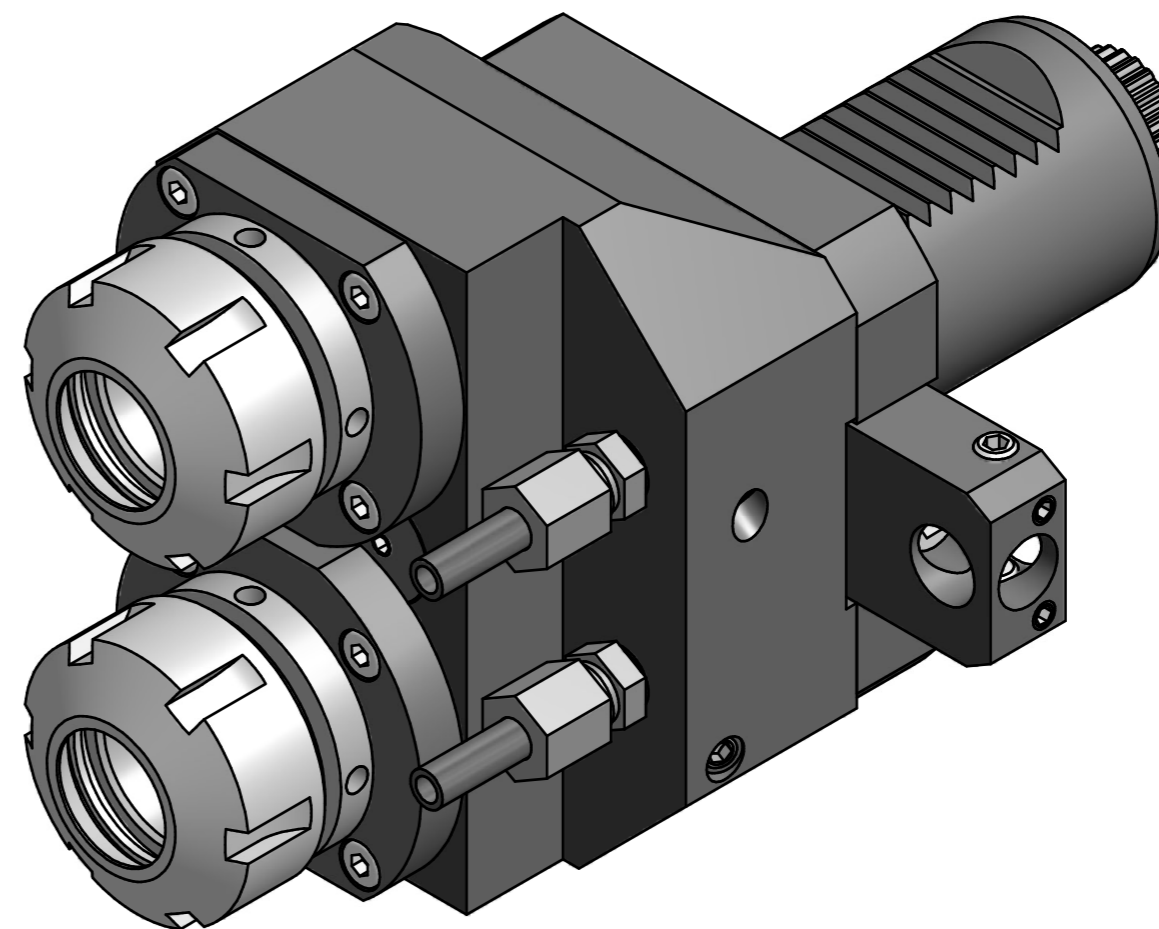

Gewindebohrzange / tapping collet  
ET-1-25 M3-M12

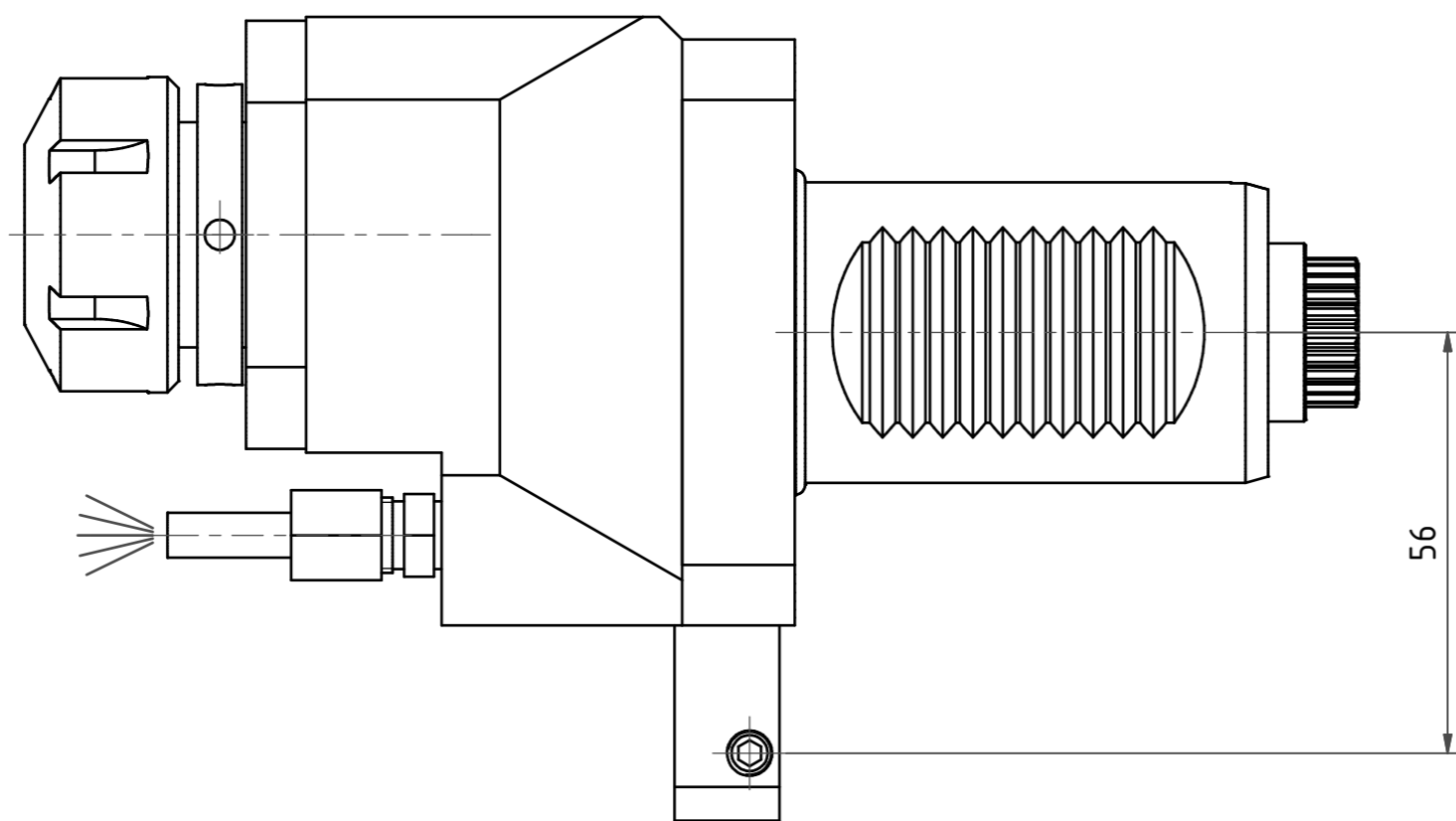

Hakenschlüssel  
mit Zapfen  
Hook wrench  
with fixed pin  
DIN1810 B 40x42

Spannzangenschlüssel  
Clamping wrench  
225

Copyright **EWS Tool Technologies**  
Weitergabe und Vervielfältigung dieser Unterlage,  
Verwertung und Mitteilung ihres Inhalts nicht  
gestattet, soweit nicht ausdrücklich zugestanden.  
Zuwendungen verpflichten zu Schadenersatz.

Bemerkung - Note	Technische Daten - technical data <b>Weight</b> = 4,266 [kg] <b>Torque max.</b> (M1/M2) = 25 / 12 each Sp. [Nm] <b>Speed max.</b> (n1/n2) = 6000 / 12000 [1/min] <b>Gear ratio</b> (i)=n1:n2 = 1:2	Benennung - Title <b>Axial Bohr und Fräskopf</b> <b>Axial drilling and milling head</b>	 <b>EWS</b> Weigle GmbH & Co. KG Maybachstr. 1 D-73066 Ulmringen www.ews-tools.de	Technische Änderungen vorbehalten! Subject to technical modifications! IDENT: D-EWS-134994 MNR.	Nr. - No. <b>40.4025DYCTXRL1TK58</b> REV: A/- <b>165003</b> 
------------------	----------------------------------------------------------------------------------------------------------------------------------------------------------------------------------------------------------------	-----------------------------------------------------------------------------------------------	---------------------------------------------------------------------------------------------------------------------------------------------------------------------------------	----------------------------------------------------------------------------------------------------------	---------------------------------------------------------------------------------------------------------------------------------------------------------------