

Spannzange / Collet ER16 DIN6499  
Spannbereich / Clamping range: 1,0 - 10,0

Gewindebohrzange / Tapping Collet  
ET-1-16 M1-M6

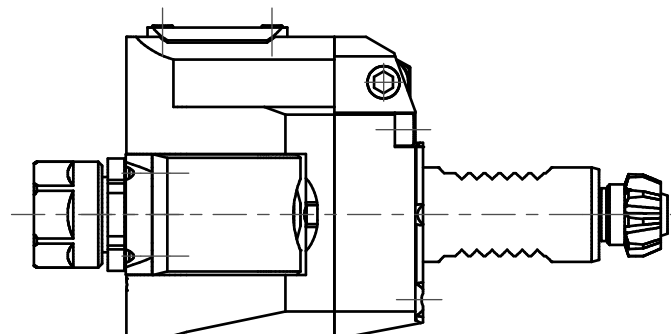

Doppelverzahnung Lizenz Traub  
double tooth system licence Traub

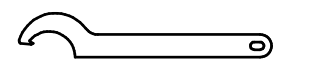
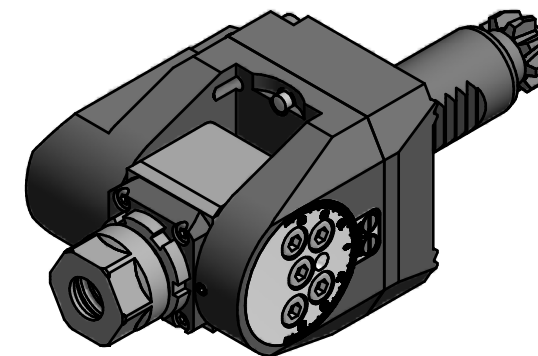

Hakenschlüssel  
mit Nase  
Hook wrench with  
nose end  
DIN1810 A 30x32

Copyright **EWS Tool Technologies**  
Weitergabe und Vervielfaeltigung dieser Unterlage,  
Verwertung und Mitteilung ihres Inhalts nicht  
gestattet, soweit nicht ausdruuecklich zugestanden.  
Zuwaiderhandlungen verpflichten zu Schadenersatz.

Bemerkung - Note

Technische Daten - technical data

Weight = 2.195 [kg]  
Torque max. (M1/M2) = 16 / 8 [Nm]  
Speed max. (n1/n2) = 6000 / 12000 [1/min]  
Gear ratio (i)=n1:n2 = 1:2

Benennung - Title

Schwenkkopf  
Swivel head

**EWS**  
Tool Technologies

EWS Weigele GmbH & Co. KG  
Maybachstr. 1  
D-73066 Utingen  
www.ews-tools.de

Technische Aenderungen vorbehalten!  
Subject to technical modifications!

IDENT: D-EWS-209904

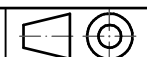

REV: -/-

Nr. - No.

63.2516ABCRLI1W

MNR.

193662

