

Spannzange / collet ER50 DIN6499  
 Spannbereich / clamping range: 6,0 - 34,0

 Hakenschlüssel  
 mit Nase  
 Hook wrench with  
 nose end  
 DIN1810 A 110x115

 Spannzangenschlüssel  
 Clamping wrench  
 250

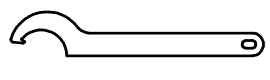
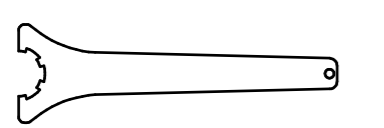
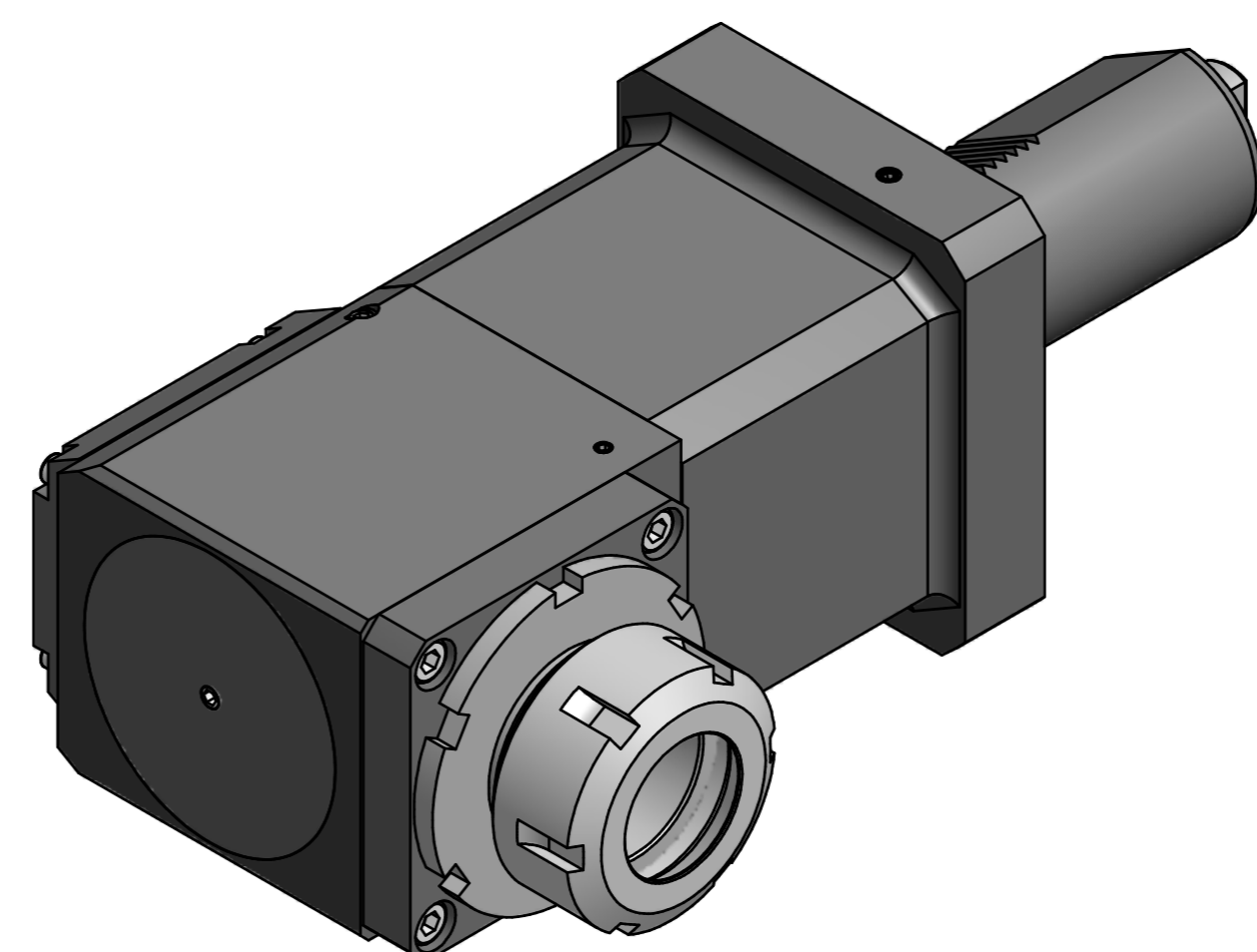

Bemerkung - Note mit Kegelrollenlager with taper roller bearing(s)	Technische Daten - technical data M <sub>1</sub> / M <sub>2</sub> = 160 / 160 Nm n <sub>1</sub> / n <sub>2</sub> = 3000 / 3000 1/min i (N <sub>1</sub> :N <sub>2</sub> ) = 1:1	Benennung - Title <b>Radial Bohr und Fräskopf</b> <b>Radial drilling and milling head</b>	<table border="1"> <tr> <th>name</th> <th>date</th> </tr> <tr> <td>Rogler</td> <td>07.08.2014</td> </tr> </table>	name	date	Rogler	07.08.2014	Technische Änderungen vorbehalten! Subject to technical modifications! Nr. <b>60.6050KRMP650R</b> MNR: 175867 IDENT: D-EWS-161207 - Blatt - page 1 (1)
name	date							
Rogler	07.08.2014							

Copyright **EWS Tool Technologies**  
 Weitergabe und Vervielfältigung dieser Unterlage,  
 Verwertung und Mitteilung ihres Inhalts nicht  
 gestattet, soweit nicht ausdrücklich zugestanden.  
 Zuwiderhandlungen verpflichten zu Schadenersatz.

