

Spannzange / collet ER32 DIN6499
 Spannbereich / clamping range: 2,0 - 20,0

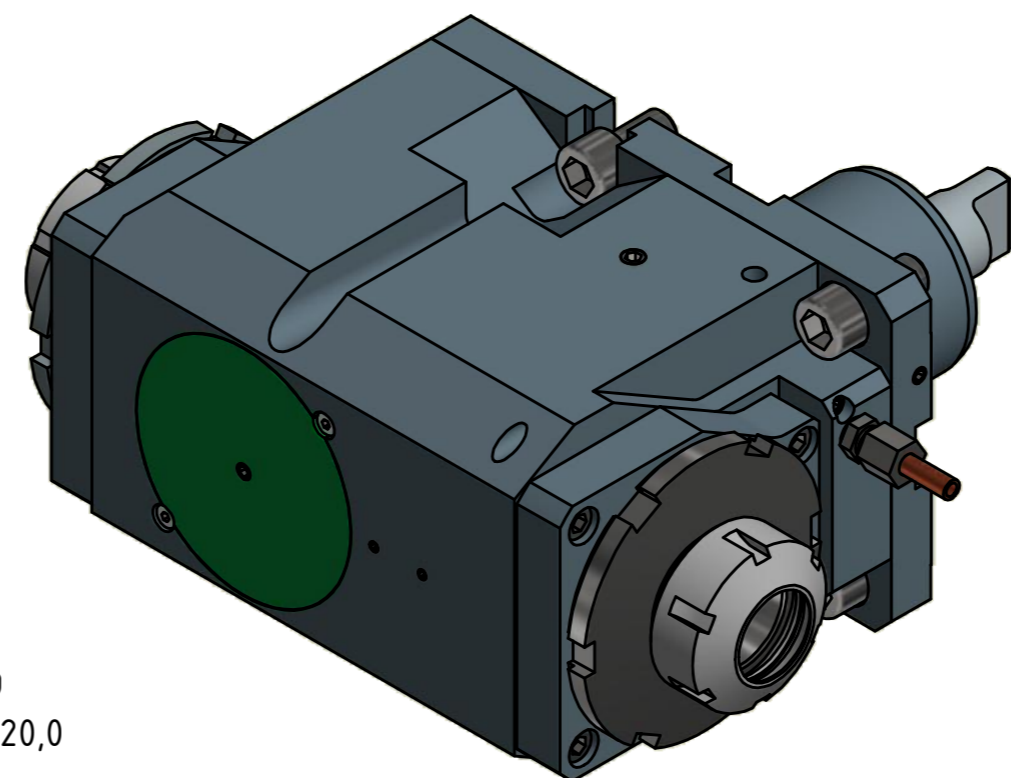
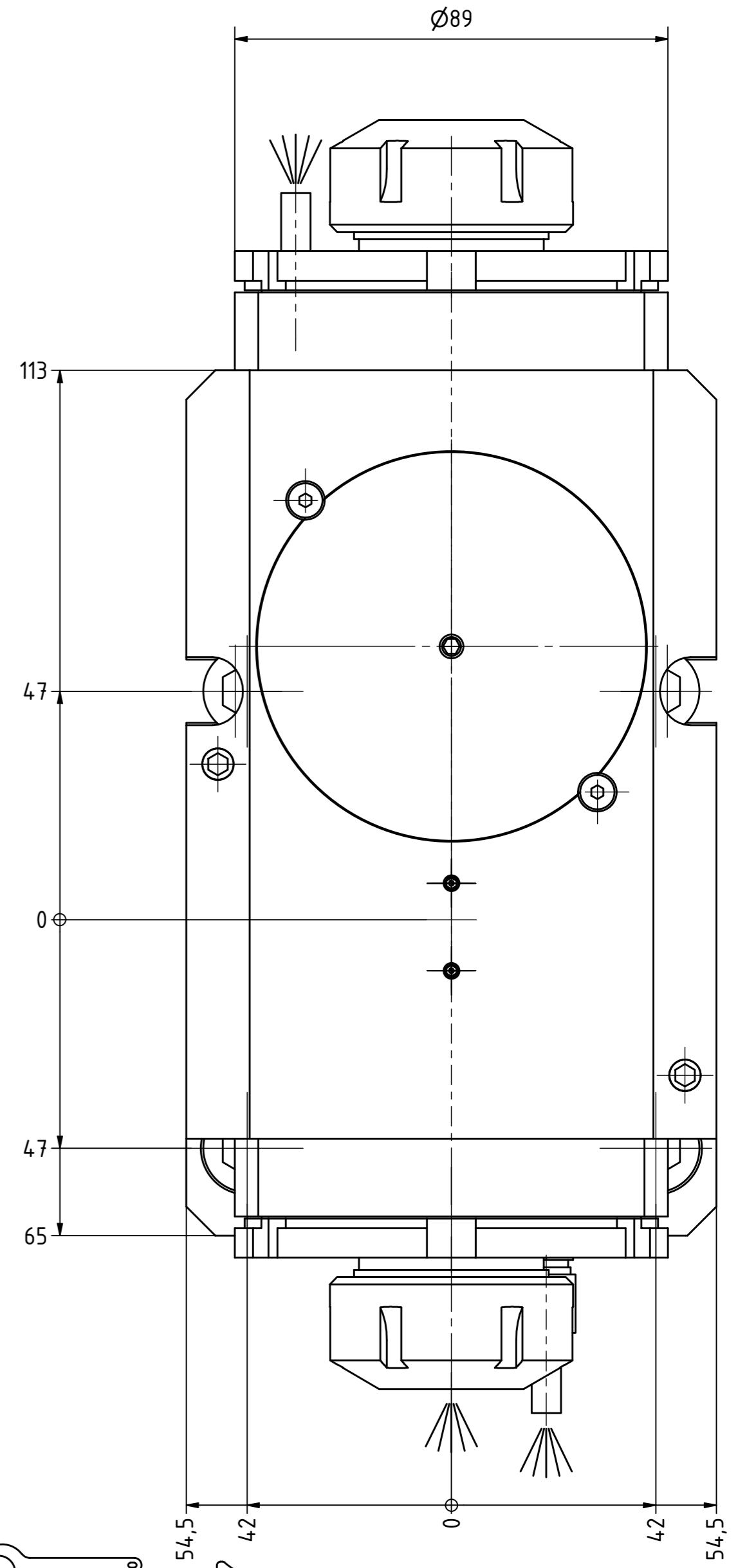
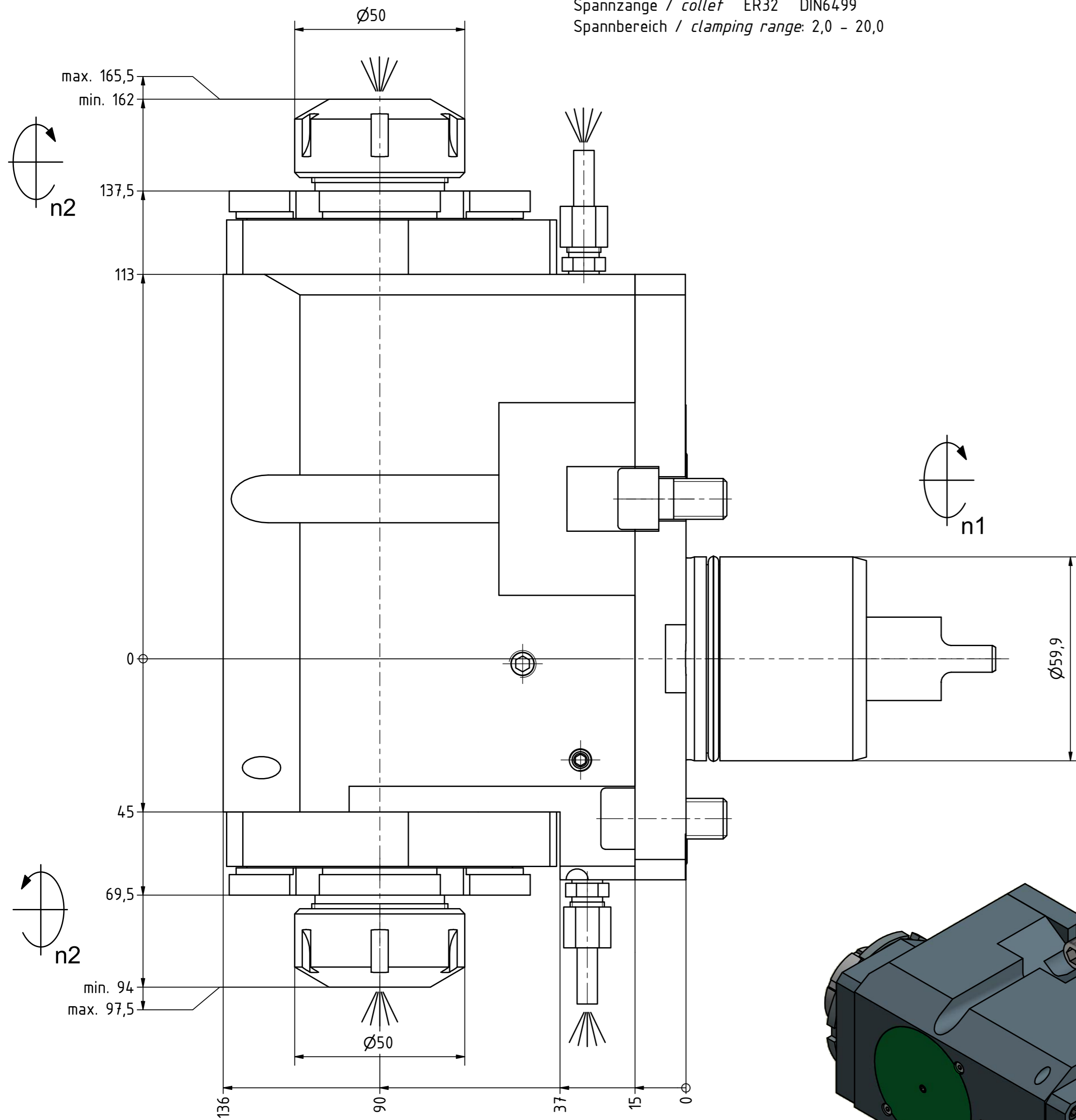

Spannzange / collet ER32 DIN6499
 Spannbereich / clamping range: 2,0 - 20,0

Hakenschlüssel mit Nase
 Hook wrench with nose end
 DIN1810 A 80x90

Spannzangenschlüssel
 Clamping wrench
 232

Copyright **EWS Tool Technologies**
 Weitergabe und Vervielfältigung dieser Unterlage, Verwertung und Mitteilung ihres Inhalts nicht gestattet, soweit nicht ausdrücklich zugestanden. Zuwiderhandlungen verpflichten zu Schadenersatz.

Innen- und Aussenkuehlung / Inside and outside coolant supply
 Kuehlmittelfiltrierung=50µ / coolant filtration=50µ

Bemerkung - Note Für Trockenlauf geeignet! Use without coolant fluid allowed!	Technische Daten - technical data Weight = 18.920 [kg] Torque max. (M1/M2) = 100 / 50 each Sp. [Nm] Speed max. (n1/n2) = 4000 / 8000 [1/min] Gear ratio (i)=n1:n2 = 1:2 Pressure (pmax) = 70 [bar]	Benennung - Title Radial Bohr und Fräskopf, zurückges Radial drill. and mill. head offset	EWS Tool Technologies EWS Weigle GmbH & Co. KG Maybachstr. 1 D-73066 Uhlingen www.ews-tool.de Nr. - No. 80.6032DNLIKD1	Technische Änderungen vorbehalten! Subject to technical modifications! IDENT: DEWS056998 MNR. REV: -/A 164494	QR
---	---	---	--	--	----