

Spannzange / collet ER20 DIN6499  
Spannbereich / clamping range: 1,0 - 13,0

Gewindebohrzange / tapping collet  
ET-1-20 M2-M6

(1:2) Doppelverzahnung Lizenz Traub  
double tooth system licence Traub

Spannzangenschlüssel für  
innenliegende Mutter  
Clamping wrench for  
internal collet  
220AX

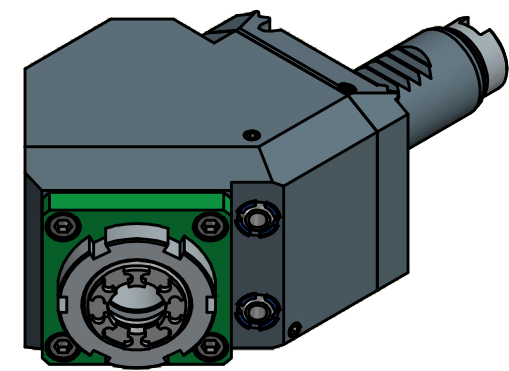
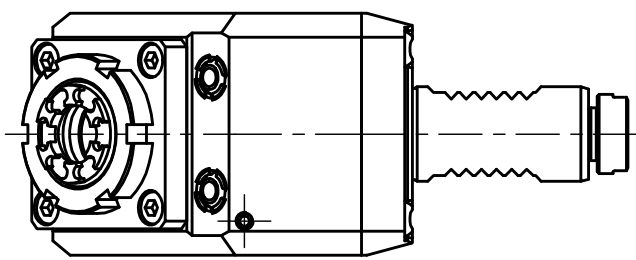
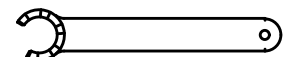

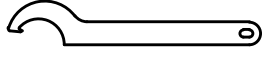
Hakenschlüssel  
mit Nase  
Hook wrench with  
nose end  
DIN1810 A 40x42

Copyright **EWS Tool Technologies**  
Weitergabe und Vervielfältigung dieser Unterlage,  
Verwertung und Mitteilung ihres Inhalts nicht  
gestattet, soweit nicht ausdrücklich zugestanden.  
Zuwiderhandlungen verpflichten zu Schadenersatz.

Bemerkung - Note

Technische Daten - technical data  
Weight = 2.732 [kg]  
Torque max. (M1/M2) = 25 / 25 [Nm]  
Speed max. (n1/n2) = 8000 / 8000 [1/min]  
Gear ratio (i)=n1:n2 = 1:1

Benennung - Title  
**Radial Bohr und Fräskopf**  
**Radial drilling and milling head**

**EWS** Tool Technologies  
EWS Weigle GmbH & Co. KG  
Maybachstr. 1  
D-73066 Uhingen  
www.ews-tools.de

Technische Änderungen vorbehalten!  
Subject to technical modifications!  
IDENT: D-EWS-140378

REV: -/-  
MNR.  
164349

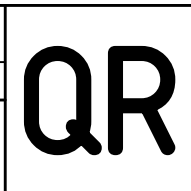

Nr. - No.  
60.2520G200RLWTKW45IM