

W-Verzahnung Lizenz Index-Werke
W-tooth system licence Index-Corporation

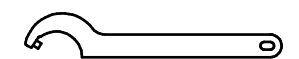

Hakenschlüssel
 mit Zapfen
*Hook wrench
 with fixed pin
 DIN1810 B 45x50*

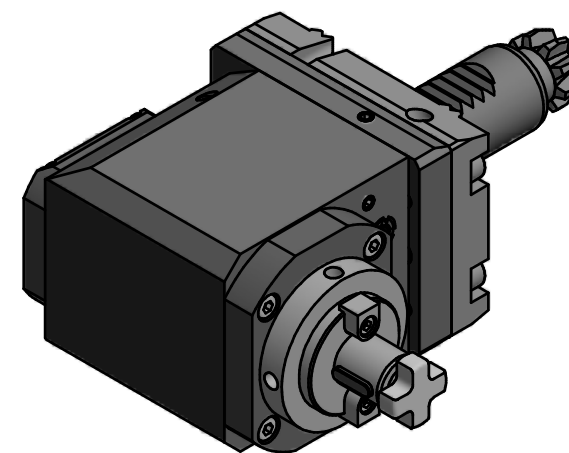
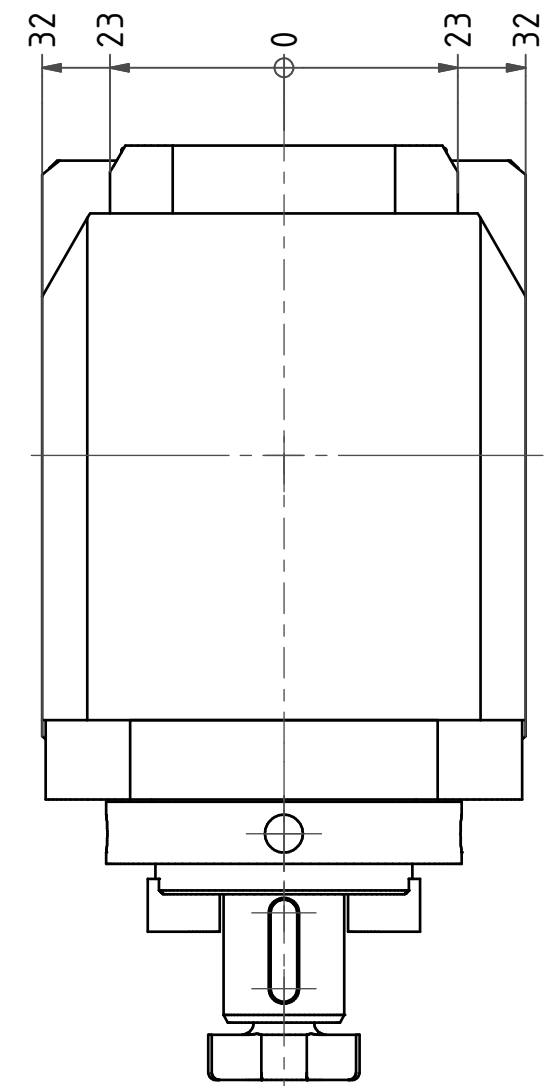
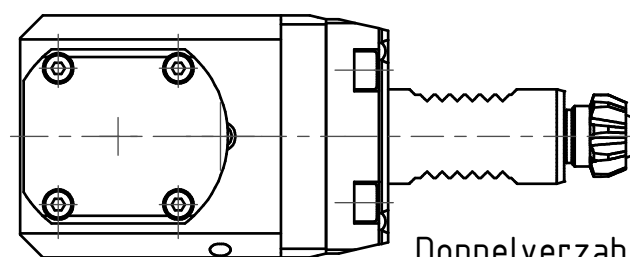

Doppelverzahnung Lizenz Traub
double tooth system licence Traub

Copyright **EWS Tool Technologies**
 Weitergabe und Vervielfältigung dieser Unterlage,
 Verwertung und Mitteilung ihres Inhalts nicht
 gestattet, soweit nicht ausdrücklich zugestanden.
 Zuwiderhandlungen verpflichten zu Schadenersatz.

Bemerkung - Note

Technische Daten - technical data

Weight = 3.458 [kg]
 Torque max. (M1/M2) = 25 / 25 [Nm]
 Speed max. (n1/n2) = 8000 / 8000 [1/min]
 Gear ratio (i)=n1:n2 = 1:1

Benennung - Title

Radial Fräskopf
Radial milling head

EWS
 Tool Technologies

EWS Weigele GmbH & Co. KG
 Maybachstr. 1
 D-73066 Uhingen
 www.ews-tools.de

Technische Änderungen vorbehalten!
Subject to technical modifications!

IDENT: D-EWS-209878

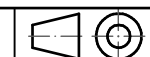

REV: -/-

Nr. - No.

62.2516ABCRLW

MNR.

193657

