

Spannzange / collet ER25 DIN6499
 Spannbereich / clamping range: 1,0 - 16,0

Gewindebohrzange / tapping collet
 ET-1-25 M3-M10

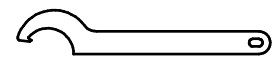

Hakenschlüssel
 mit Nase
*Hook wrench with
 nose end*
 DIN1810 A 45x50

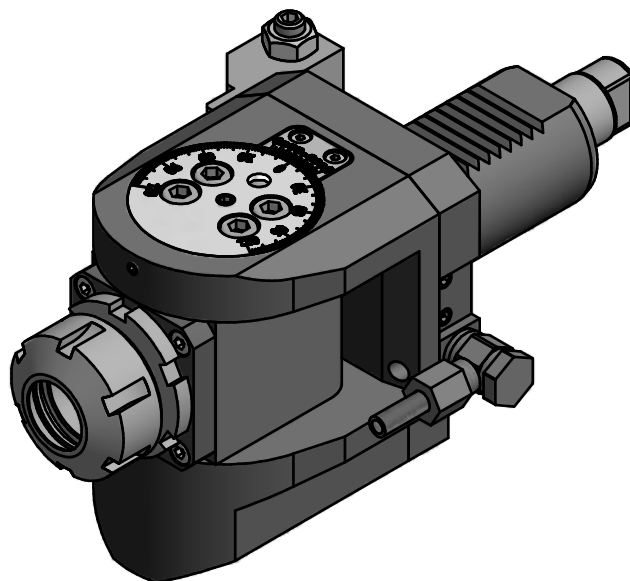
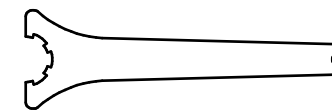

Spannzangenschlüssel
Clamping wrench
 225

Eine Nachbarstation nicht verwendbar!
A neighbouring stations can not be used!

Copyright **EWS Tool Technologies**
 Weitergabe und Vervielfaeltigung dieser Unterlage,
 Verwertung und Mitteilung ihres Inhalts nicht
 gestattet, soweit nicht ausdruercklich zugestanden.
 Zuwiderhandlungen verpflichten zu Schadenersatz.

Bemerkung - Note	Technische Daten - technical data Weight = 4.543 [kg] Torque max. (M1/M2) = 20 / 20 [Nm] Speed max. (n1/n2) = 6000 / 6000 [1/min] Gear ratio (i)=n1:n2 = 1:1	Benennung - Title Schwenkkopf <i>Swivel head</i>	 EWS Weigele GmbH & Co. KG Maybachstr. 1 D-73066 Uthingen www.ews-tools.de	Technische Aenderungen vorbehalten! <i>Subject to technical modifications!</i> IDENT: D-EWS-206614 Nr. - No. 63.4025LARU	 REV: -/- MNR. 193737	
------------------	--	---	--	---	---------------------------------------	--