

Spannzange / collet ER25 DIN6499
Spannbereich / clamping range: 1,0 - 16,0

Gewindebohrzange / tapping collet
ET-1-25 M3-M12

Z (2:1)

Ausrichtklotz ist über ein Exzenter einstellbar.
The block is adjustable via eccentric.

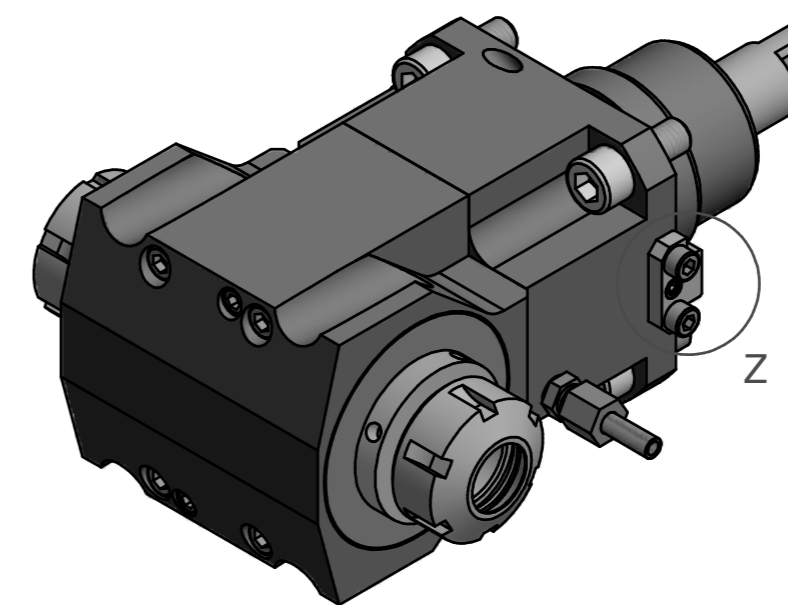
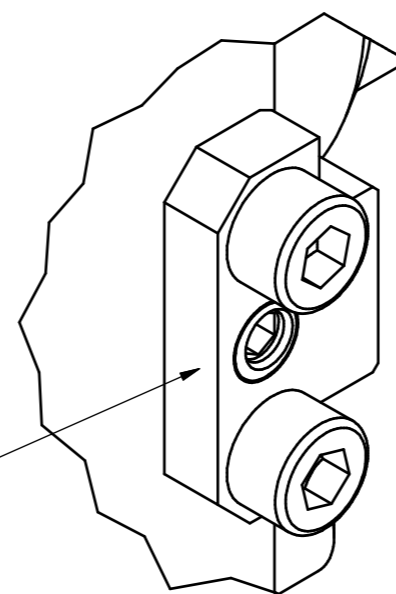

Hakenschlüssel mit Zapfen
Hook wrench with fixed pin
DIN1810 B 45x50

Spannzangenschlüssel
Clamping wrench
225

Copyright **EWS Tool Technologies**
Weitergabe und Vervielfältigung dieser Unterlage, Verwertung und Mitteilung ihres Inhalts nicht gestattet, soweit nicht ausdrücklich zugestanden. Zuwiderhandlungen verpflichten zu Schadenersatz.

| | | | | | |
|----------------------|--|---|---|---|---|
| Bemerkung - Note | Technische Daten - technical data Weight = 7.607 [kg] Torque max. (M1/M2) = 50 / 50 [Nm] Speed max. (n1/n2) = 6000 / 6000 [1/min] Gear ratio (i)=n1:n2 = 1:1 | Benennung - Title Radial Bohr und Fräskopf Radial drilling and milling head | EWS Tool Technologies <small>EWS Weigle GmbH & Co. KG Maybachstr. 1 D-73066 Ultingen www.ews-tools.de</small> | Technische Änderungen vorbehalten! Subject to technical modifications! IDENT: D-EWS-210606 Nr. - No. 60.5525DBIG1809X100 | MNR. REV: -/- 164490  |
|----------------------|--|---|---|---|---|